

30 Mln/1m  
IP-X7

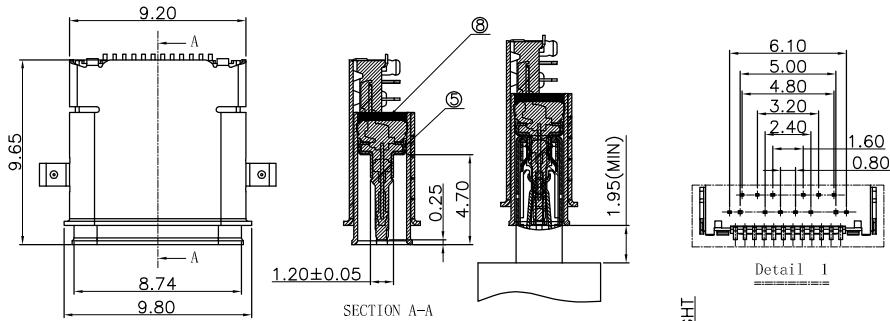

Pin	Signal Name	Mating Sequence	Pin	Signal Name	Mating Sequence
A1	GND	First	B12	GND	First
A2	SSTxp1	Second	B11	SSRXp1	Second
A3	SSTxn1	Second	B10	SSRXn1	Second
A4	V <sub>bus</sub>	First	B9	V <sub>bus</sub>	First
A5	CC1	Second	B8	SBU2	Second
A6	Dp1	Second	B7	Dn2	Second
A7	Dn1	Second	B6	Dp2	Second
A8	SBU1	Second	B5	CC2	Second
A9	V <sub>bus</sub>	First	B4	V <sub>bus</sub>	First
A10	SSRXn2	Second	B3	SSTXn2	Second
A11	SSRXp2	Second	B2	SSTXp2	Second
A12	GND	First	B1	GND	First
SHELL	GND		SHELL	GND	

Detail 1

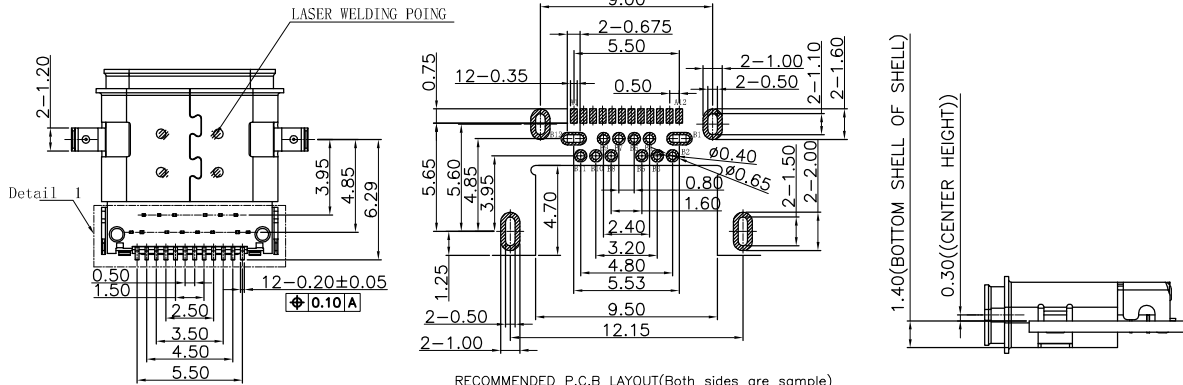
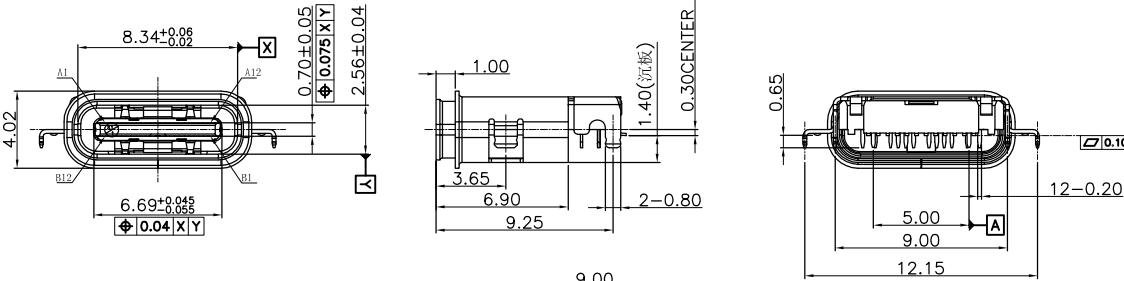

RECOMMENDED P.C.B LAYOUT(Both sides are sample)  
Tolerance:±0.05, Thickness=0.60mm

- NOTES:
- MATERIAL: SEE "TABLE 1"横
  - FINISH: SEE "TABLE 1"横
  - ELECTRICAL :
    - CONTACT CURRENT RATING :  
5A(VBUS PIN 1.5A/PIN),  
5A(GND PIN 1.25A/PIN MAX),0.25A/PIN(OTHER PIN).
    - INSULATION RESISTANCE :  
100 MEGAOHMS MIN. AT 250VDC.
    - DIELECTRIC WITHSTANDING VOLTAGE :  
100VAC MIN.
    - LOW LEVEL CONTACT RESISTANCE :  
INITIAL 40mΩ MAX.  
AFTER 50mΩ MAX.
  - MECHANICAL CHARACTERISTICS :
    - MATING FORCE: 5~20N.横
    - UNMATING FORCE: 8~20N(INITIAL),6~20N(AFTER 10000 CYCLES);
    - DURABILITY : 10,000 MATING CYCLES.
    - OPERATING TEMPERATURE : -40°C TO +80°C

Part no.  
349 A G 24 B X I A5 N 2 C 3  
1 2 3 4 5 6 7 8 9 10 1112

- SERIES NO.
- TYPE:A=Standard  
A5=USB 3.1 CF
- GREEN OPTION:  
G=RoHS+HF(Bright Plated)
- CONTACT NUMBER:  
24=24 Pin
- CONTACT TYPE  
B=Female(LCP)  
C=15u" Gold  
R=3u" Gold
- CONTACT AREA PLATING:  
T=TIN
- APPLY TYPE:  
A5=USB 3.1 CF
- SHELL PLATING:  
N=Nickel
- TYPE.  
2=Center Height 0.3mm
- PACKING STYLE:  
C=Tpae & Reel
- INSULATOR COLOR:  
3=Black

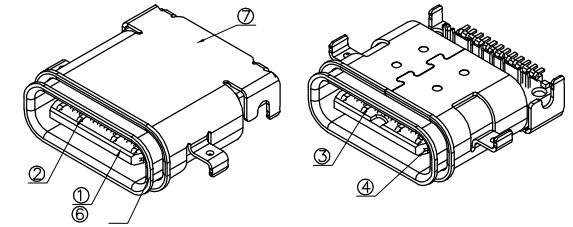

TABLE 1:

NO.	PART NAME	QTY	MATERIAL	DESCRIPTION	REMARK
⑧	GLUE WATER	1	EPOXY	BLACK;	
⑦	Shell-2	1	Stainless steel	NI PLATING;	T=0.20mm
⑥	Shell-1	1	Stainless steel	NI PLATING;	T=0.20mm
⑤	GND PLATE	1	Stainless steel	NI PLATING;	T=0.10mm
④	MID PLATE	1	Stainless steel		T=0.15mm
③	Terminal-B	12	铜镍硅合金	Au 3u" or Au 15u"	T=0.12mm
②	Terminal-A	12			T=0.12mm
①	Housing	1	HIGH TEMP	Black	

UNLESS OTHERWISE SPECIFIED TOLERANCE  
X. ±5°  
X. ±0.38  
X.x ±0.30  
X.xx ±0.20



CHANT SINCERE CO.,LTD  
TEL:886-02-86471251 FAX:886-02-86472962

For SIP

SCALE:	AS SHOWN	UNIT:	mm
DRAWN	Michelle	29/03/2021	Title
CHECKED	Pearl	29/03/2021	Part NO.
APPROVED	Pearl	29/03/2021	349AG24BXTA5N2C3

USB 3.1 CF WATERPROOF  
Cl.=0.30 沉板1.40mm DIP TYPE

1/3

Code:	R07	Customer:	
-------	-----	-----------	--

Zone Revision DESCRIPTION DATE

DATE

SIZE A4 REV. B

Code: R07

Customer:

30 Min/1m  
IP-X7

# 建议密封方式

机壳面板

机壳面板对密封圈与缩量0.30Min  
(建议压缩量为密封圈直径大小40-50%)

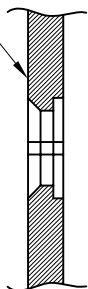

密封圈

PCB板

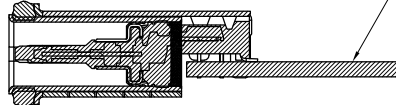

前后组装方式

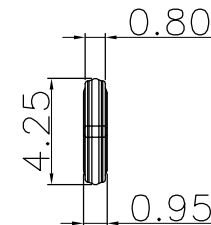
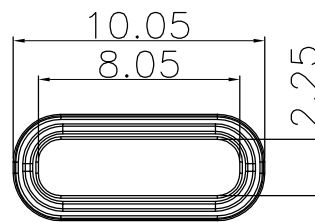

建议防水圈规格 (材质硅橡胶)

机壳面板对密封圈与缩量0.30Min  
(建议压缩量为密封圈直径大小40-50%)

密封圈

PCB板

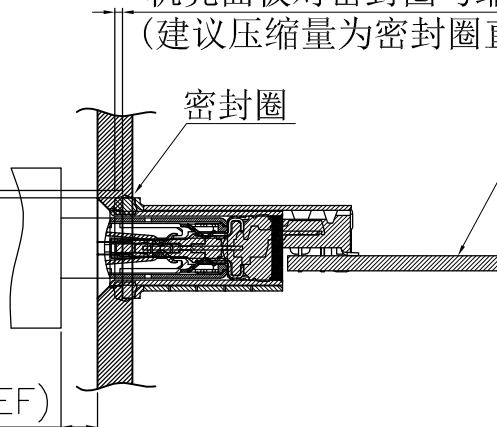

1.45(REF)

组装面板后公母头对插示意图

UNLESS OTHERWISE SPECIFIED TOLERANCE  
X. ±5°  
X. ±0.38  
X.x ±0.30  
X.xx ±0.20

SCALE: AS SHOWN UNIT: mm

DRAWN Michelle 29/03/2021

CHECKED Pearl 29/03/2021

APPROVED Pearl 29/03/2021



CHANT SINCERE CO.,LTD  
TEL:886-02-86471251 FAX:886-02-86472962

Title: USB 3.1 CF WATERPROOF  
Cl.=0.30 沉板1.40mm DIP TYPE

Part NO. 349AG24BXTA5N2C3

Code: R07 Customer:

Zone	Revision	DESCRIPTION	DATE	SIZE	REV.	Code	Customer
1				A4	B	R07	

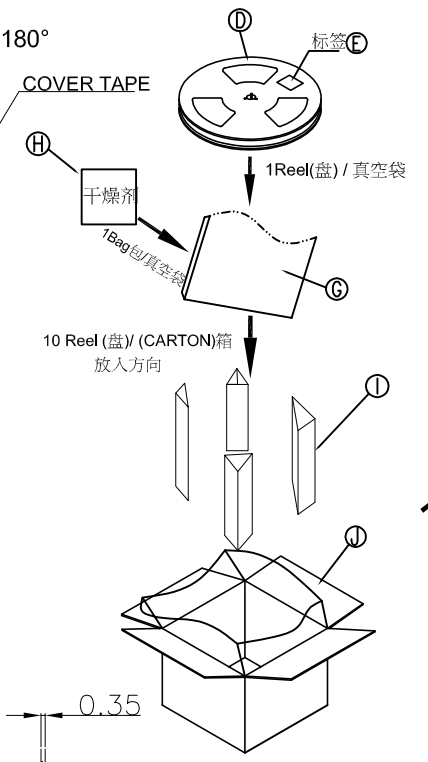
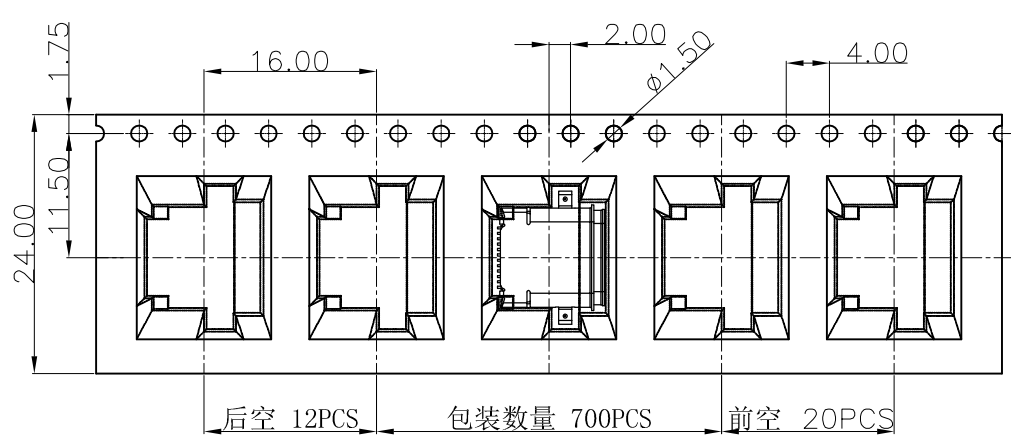
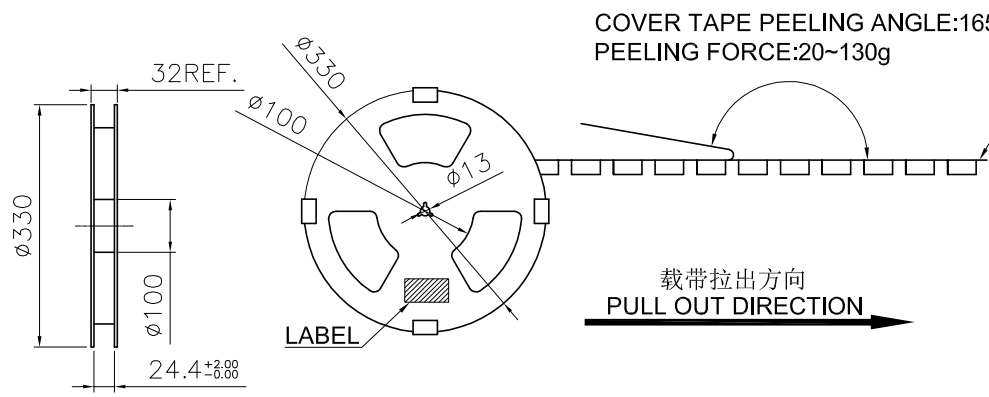

包装方式:  
 第一步: 产品使用包装机器入包装盘  
 (1) 首先将包装盘贴上标签  
 (2) 再将成品按照规定的所示方向摆放于料带中进行包装  
 (3) 每盘包装数量700PCS成品  
 第二步: 包装盘入外箱  
 (1) 将包装完的包装盘每1盘装入1个真空袋中  
 (2) 每个真空袋中放入一包干燥剂, 并做真空包装处理  
 (3) 将10个真空袋, 共10盘/7000PCS放入置入外箱的PE袋中  
 第三步: 外箱封口&贴标签  
 (1) 先确认外箱里是否有10盘产品  
 (2) 包装完成后使用透明胶带封口, 贴LABEL于规定的位置  
 第四步: 储存&运输  
 (1) 储存在通风, 干燥环境; 搬运时轻拿轻放

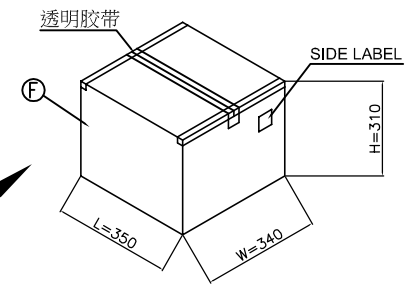

防水胶圈包装(两者独立包装)

5000	6	30000
PCS/BAG	BAG/CASE	PCS/CASE

J	PE袋	1	630L*620W
I	三角护柱	4	
H	干燥剂	10	
G	真空袋	10	500L*450W
F	纸箱	1	350L*340W*310H
E	标签	10	
D	REEL	10	
C	COVER TAPE	10	21.3m/m (1R/300M)
B	CARRIER TAPE	10	12511(L)*24(W)*0.4(T)
A	TYPE C	7000	
NO	DESCRIPTION	Q'TA(PCS)	SPEC

UNLESS OTHERWISE SPECIFIED TOLERANCE

X.xxx	±0.10	ANGULAR:	X.xx	±1'
X.xx	±0.20		X.x	±3'
X.x	±0.30		X.	±5'
X.	±0.38			

SCALE:	AS SHOWN	UNIT:	mm
DRAWN	Michelle	29/03/2021	
CHECKED	Pearl	29/03/2021	
APPROVED	Pearl	29/03/2021	

**CHANT SINCERE CO.,LTD**  
 TEL:886-02-86471251 FAX:886-02-86472962

Title: USB 3.1 CF WATERPROOF  
 CL=0.30 沉板1.40mm DIP TYPE  
 包装图

Part NO. 349AG24BXTA5N2C3

Code: R07 Customer:

Zone	Revision	DESCRIPTION	DATE
1			
2			
3			
4			
5			
6			

3/3