

RoHS  
compliant

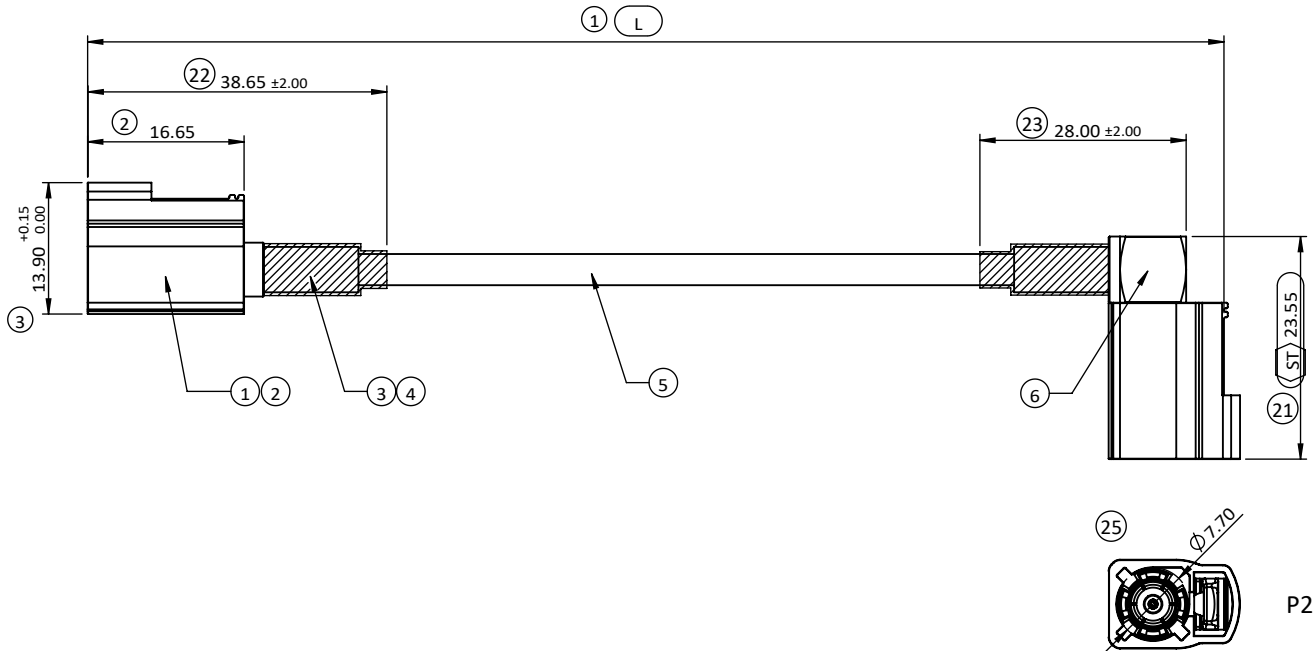

**SPECIFICATION**  
**ELECTRICAL CHARACTERISTIC:**  
 1. CHARACTERISTIC IMPEDANCE: 50 Ω  
 2. FINISHED CABLE 100% CONDUCTIVITY TEST

**ENVIRONMENT:**  
 1. OPERATING TEMPERATURE RANGE: -40°C TO +105°C

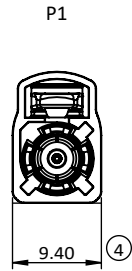

6	1410202005Z	N/A	720±15mm	Z/Z CODE	W/ COXOC LOGO	
5	1410202004Z	C7S74ZZ3A01SE2M0	2000±50mm	Z/Z CODE	W/ COXOC LOGO	
4	1410202003Z	C7S74ZZ3A01SE1M0	1000±30mm	Z/Z CODE	W/ COXOC LOGO	
3	1410202002Z	C7S74ZZ3A01E3M0	3000±50mm	Z/Z CODE	W/O LOGO	
2	1410202001Z	C7S74ZZ3A01E1M0	1000±30mm	Z/Z CODE	W/O LOGO	
1	1410202001A	C7S74AA3A01E1M0	1000±30mm	A/A CODE	W/O LOGO	
ITEM	NEW P/N	OLD P/N	L ( LENGTH )	CODING	LOGO	NOTE

UNLESS OTHERWISE SPECIFIED TOLERANCE	
ANG.	+2°
0.	+0.30
.0	+0.20
.00	+0.10

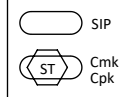

6	FAKRA JACK R/A	BRASS, TEFLON WHITE, CONNECT ,1~3u" AU PLATED	1
5	CABLE	(RTK031)22AWG COAXIAL + AL-MYLAR+BRALA ID: 3.2 ±0.1, JACKET: PVC, BLACK	1
4	HST	HEAT SHRINK TUBE, ID: 5.0, BLACK	1
3	COPPER TUBE	BRASS, 100~130u" NI PLATED	1
2	FAKRA JACK STR	BRASS, TEFLON WHITE, CONNECT ,1~3u" AU PLATED	1
1	CODING HOUSING	XPBT 1300, UL94V-0	1
ITEM	DESCRIPTION	MATERIAL	Q'TY

	G	ECN-2507036(VANESSA)SEE PAGE 1/3	14JUL2025	DRAWN: RITA_CHANG	14 Jul 2025	TITLE: PDR-21021 FAKRA JACK TO JACK CABLE (CNC VERSION)
C6	F	ECN-2406096(JOAN)ADD P/N	25JUN2024	CHECKED: PEARL_HUNG	14 Jul 2025	
C6	E	ECN-2402064(JOAN)ADD P/N	28FEB2024	APPROVED: PEARL_HUNG	14 Jul 2025	
ZONE	REVISION	DESCRIPTION	DATE	④	SIZE A4 SHEET 1/3	REV. G
1	2	3	4	5	6	7
						8
						9
						10



**RoHS**  
compliant

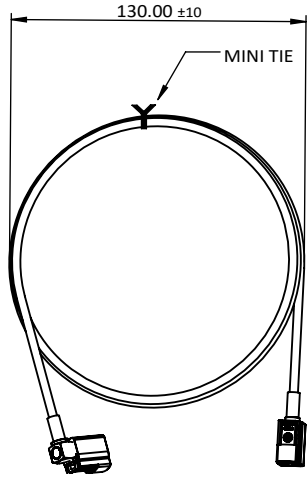

FAKRA JACK TO JACK CABLE

+

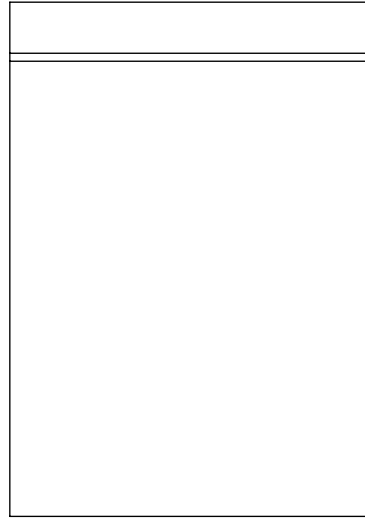

ZIP BAG:240(L)x170(W)xT0.05mm

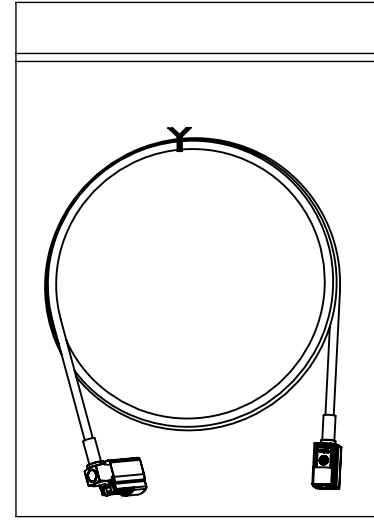

FAKRA JACK TO JACK CABLE

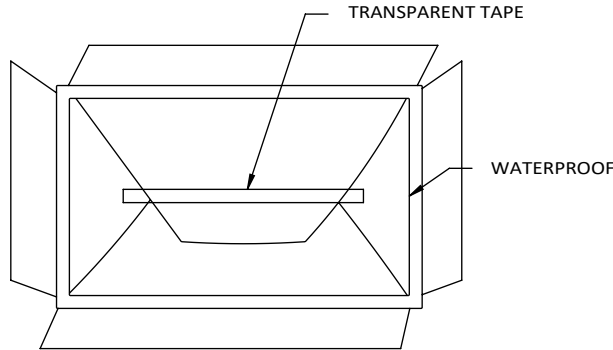
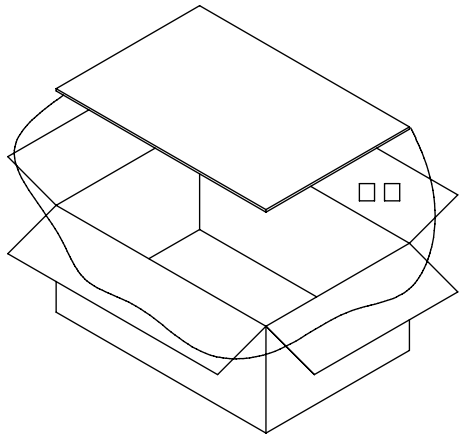

(AFTER THE INSTALLED PRODUCT,  
CARTON SEALING TAPE SHOULD BE TRANSPARENT)

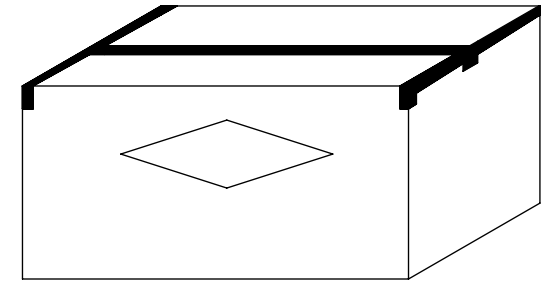

(THE PACKING QUANTITY IS BASED ON  
THE FIRST BATCH OF ACTUAL ORDER )



5	DESICCANT	M90000EZ0000029	2g	5 PCS/CARTON	
4	WATERPROOF	M9BE71163507009	28"x25"x0.07mm	1 PC/CARTON	
3	CARDBOARD(B3B)	M9EE350220000300	350x220mm	2 PCS/CARTON	
2	CARTON	M9CE356241241500	14"x9.5"x9.5"	1 PC/CARTON	
1	ZIP BAG	M9BE24017000811	240(L)x170(W)mm	1 PC CABLE/ZIP BAG	
ITEM	NAME	PART NO.	SPECIFICATION	AMOUNT	NOTE

UNLESS OTHERWISE SPECIFIED TOLERANCE	
ANG.	+5°
0.	+0.50
.0	+0.30
.00	+0.20

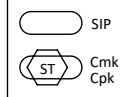

**CHANT SINCERE CO.,LTD**

B1	G	ECN-2507036(VANESSA)SEE PAGE 1/3		14JUL2025
	F	ECN-2406096(JOAN)ADD P/N		25JUN2024
	E	ECN-2402064(JOAN)ADD P/N		28FEB2024
ZONE	REVISION	DESCRIPTION		DATE
1	2	3	4	5

SCALE:	AS SHOWN	UNIT:	mm
DRAWN:	RITA_CHANG	14 Jul 2025	
CHECKED:	PEARL_HUNG	14 Jul 2025	
APPROVED:	PEARL_HUNG	14 Jul 2025	
SIZE	A4	SHEET	3/3
REV.	G		

TITLE: PDR-21021	
FAKRA JACK TO JACK CABLE (CNC VERSION)	
PART NO.	1410202XXXX
CODE:	CUSTOMER:
8	9