

NOTE:

1. THE CABLE ASSEMBLY SHOULD BE RoHS2.0 COMPLIANT.
2. ELECTRICAL AND MECHANICAL PERFORMANCE SHOULD MEET THE PCIe GEN4 INDUSTRIAL STANDARD.
3. THE CABLE ASSEMBLY SHALL MEET BELOW IMPEDANCE REQUIREMENT:
TERMINATION AREA: 85±15% OHMS, CABLE ABSOLUTE AREA: 85±10% OHMS.

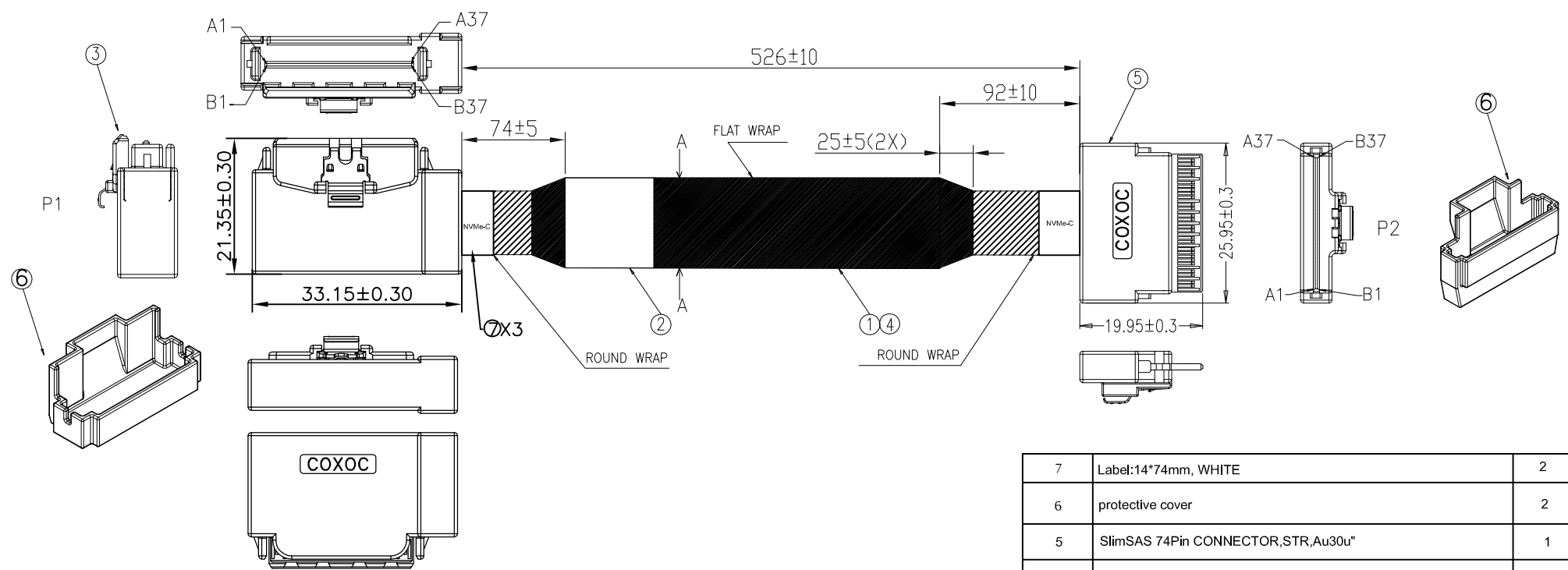

PART NO
C10 M2 1 3 B01 E 526
 1 2 3 4 5 6 7

- 1.SERIES NO.
C10=SATA TYPE
- 2.CONNECTOR OPTION
M2=LP SlimSAS 8X(37*2)
LS/SlimSAS 8X(37*2)STR
- 3.STRCONNECTOR TYPE
1=M/M
- 4.CABLE COLOR
3=BLACK
- 5.TYPE.
- 6.GREEN OPTION:
E=RoHS
- 7.LENGTH NO.
526=526mm

7	Label:14*74mm, WHITE	2
6	protective cover	2
5	SlimSAS 74Pin CONNECTOR,STR,Au30u"	1
4	ACETOUS Tape, Black	A/R
3	8X LOW PROFILE SlimSAS LS PLUG,Au30u"	1
2	Label:70*40mm,Blank,WHITE	1
1	SAS CABLE:UL20744(#30x2C+2D+AM)*12+M,Silverd,YEL-GRN 85 Ohm 24G	A/R
ITEM	DESCRIPTION	QTY

UNLESS OTHERWISE SPECIFIED TOLERANCE		 CHANT SINCERE CO.,LTD TEL:886-02-86471251 FAX:886-02-86472962
ANG.	±0°	
0.	±0	
.0	±0.50	
.00	±0.30	
SCALE: AS SHOWN	UNIT: mm	DRAWN NAME: (PDR-18100) LOW PROFILE SlimSAS X8 LS TO SlimSAS X8 STR CABLE ASSEMBLY 1/2 PRODUCT NO. C10M213B01E526 FILE NAME: C10M213B01E526(GB)
DRAWN Yang	04/22/2019	
CHECKED	/ /	
APPROVED	/ /	

REV.	DESCRIPTION	DATE	SIZE	REV.	FILE NAME:
1			A4	X3	C10M213B01E526(GB)

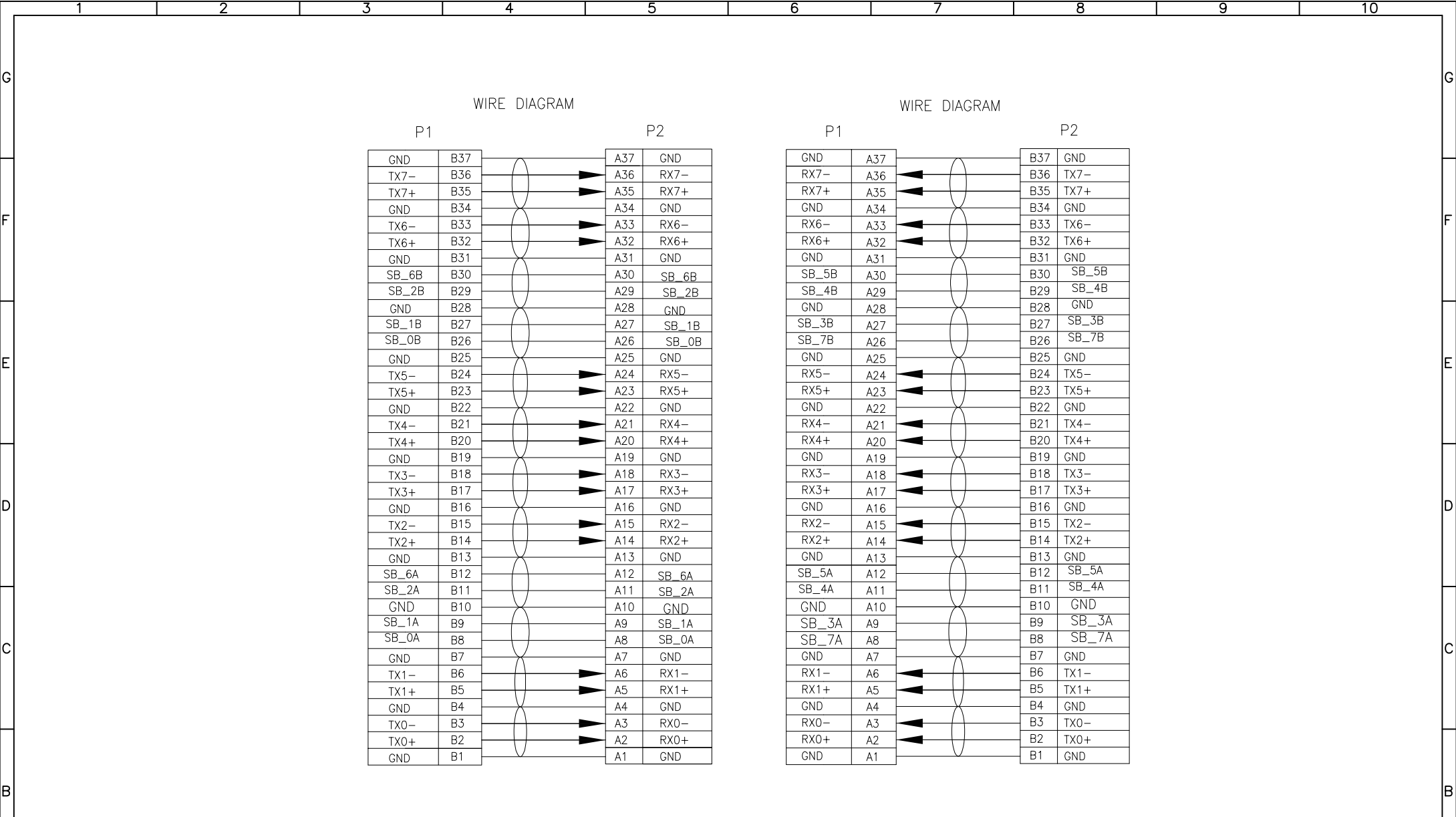

UNLESS OTHERWISE SPECIFIED TOLERANCE
 ANG. ±0°
 0. ±0
 .0 ±0.50
 .00 ±0.30



CHANT SINCERE CO., LTD
 TEL:886-02-86471251 FAX:886-02-86472962

SCALE: AS SHOWN UNIT: mm

DRAWN Yang 04/22/2019

CHECKED / /

APPROVED / /

DRAWN NAME: (PDR-18100)

LOW PROFILE SlimSAS X8 LS TO SlimSAS X8 STR CABLE ASSEMBLY 2/2

PRODUCT NO. C10M213B01E526

FILE NAME: C10M213B01E526(GB)

REV.	DESCRIPTION	DATE

SIZE A4 REV. X3