

NOTE:

1. ELECTRICAL AND MECHANICAL PERFORMANCE SHOULD MEET THE SAS3.0 INDUSTRIAL STARDAND.

电气和机械特性遵循SAS3.0工业标准.

2. HE CABLE ASSEMBLY SHOULD BE RoHS2.0 COMPLIANT.

该产品通过RoHS2.0认证.

3. CONNECTOR ORIENTATION SHOULD FOLLOW THE DRAWING.

接头朝向以图面为准.

4. 按图示测量

5. 拉直测量

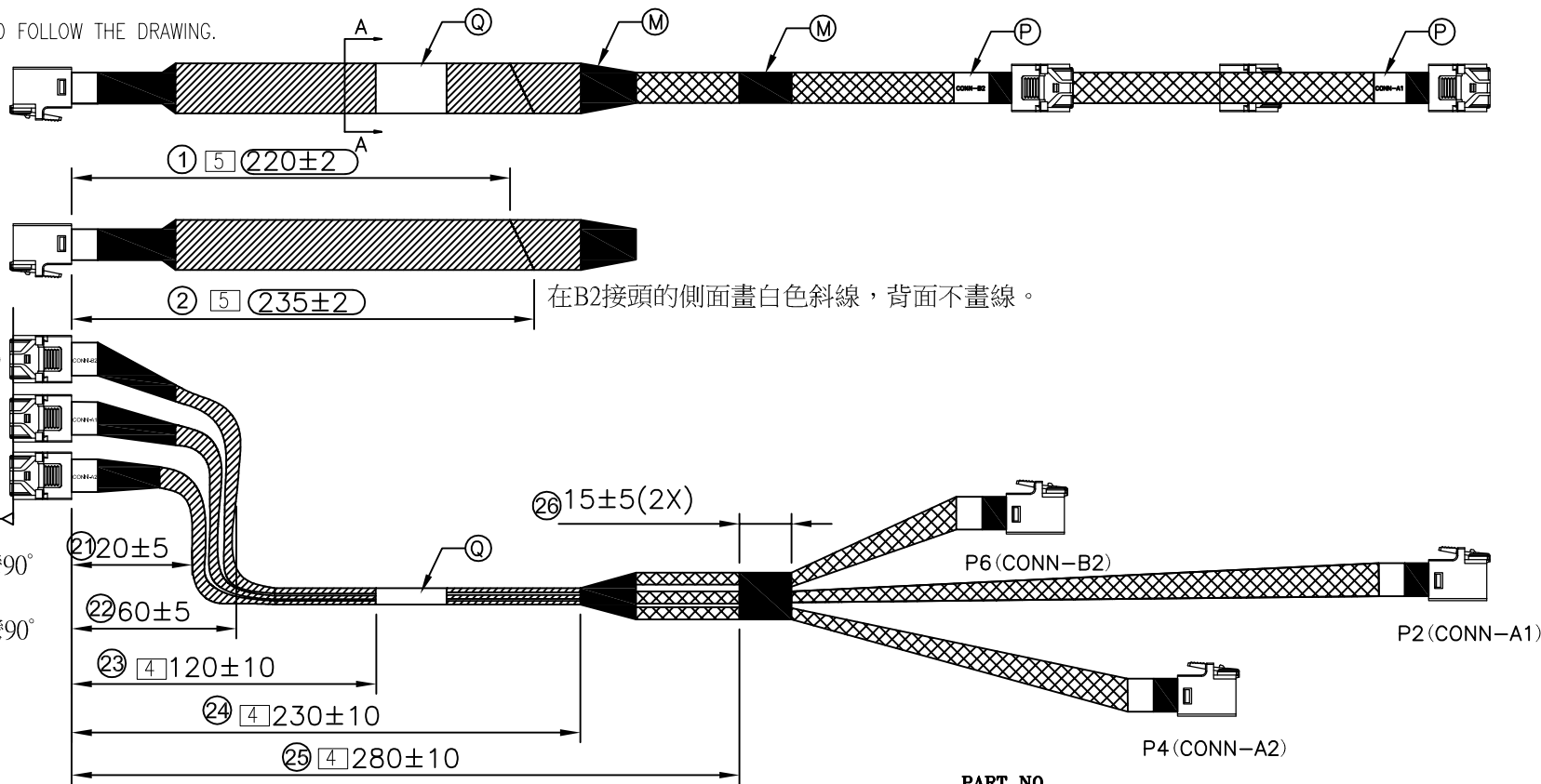

PART NO.

C10 C2 1 3 B05 E 01
1 2 3 4 5 6 7

1.SERIES NO.

C10=SATA TYPE

2.CONNECTOR OPTION

C2=HD Mini SAS

3.CONNECTOR TYPE

1=M/M

4.CABLE COLOR

3=Black

5.TYPE.

6.GREEN OPTION:

E=RoHS

7.LENGTH.

01=See Table 1.

UNLESS OTHERWISE SPECIFIED TOLERANCE

ANG. ±3°
.0 ±0.30
.00 ±0.20



CHANT SINCERE CO., LTD

TEL:886-02-86471251 FAX:886-02-86472962

SCALE: AS SHOWN UNIT: mm

DRAWN RILEY 04/18/2019

CHECKED / /

APPROVED / /

DRAWN NAME:
HD MINI SAS 36P/HD MINI SAS 36P
Cable 1/2

PRODUCT NO. C10C213B05E01

FILE NAME: C10C213B05E01(25)

REV.	DESCRIPTION	DATE	SIZE	REV.
1			A4	X8

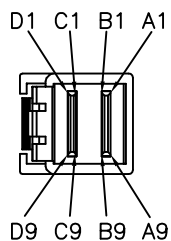

Conn. 扭轉此方向，
在貼厚的醋酸布

P1/P3/P5

NOTES:

1. P1 MOULD NO.: DM2-J701.
2. ELECTRONIC TEST:
 - 2.1. 100% OPEN; SHORT OR MISWIRE TEST;
 - 2.2. INSULATION RESISTANCE: DC300V 20M OHMS(MIN);
 - 2.3. CONTACT RESISTANCE: 1 OHMS(MAX);
 - 2.4. VOLTAGE TEST: DC300V/0.01S
3. R2E=ROHS2.0+REACH.
4. ELECTRICAL AND MECHANICAL PERFORMANCE SHOULD MEET THE SAS3.0 INDUSTRIAL STANDARD.

Table 1.

Cable No	Length	Label content
P1P2	760±5	CONN-A1
P3P4	590±10	CONN-A2
P5P6	510±10	CONN-B2

Q	LABEL	W40*L100mm, WHITE
P	LABEL	W11*L30mm, WHITE
□	TAPE	ACETATE CLOTH TAPE, W:50mm T:0.2mm, BLACK
N	TAPE	ACETATE CLOTH TAPE, W:20mm T:0.13mm, BLACK
M	TAPE	ACETATE CLOTH TAPE, W:20mm T:0.2mm, BLACK
L	TAPE	ACETATE CLOTH TAPE, W:55mm T:0.13mm, BLACK
K	N.B.T	Nylon Braided tube, BLACK
J	InnerMold-1	PP, BLACK
I	InnerMold-2	PE, Transparent+UV Glue
H	TIN	TIN STICK, TIN WIRE
G	FOAM	HD MiniSAS72P, CR, BLACK
F	FOAM	HD MiniSAS36P, CR, BLACK
D	CONN	4X HD MINI SAS STR, PA66, BLACK
C	PCB	HD MINI SAS 36P PCB/100 ohm
B	Cable	UL2651 CABLE FLAT 30#*4C*PH0.82mm GRAY
A	Cable	UL20744 30#*2C*+2D+AL+MYLAR BLUE 12G
NO	TITLE	DESCRIPTION

REV.	DESCRIPTION	DATE

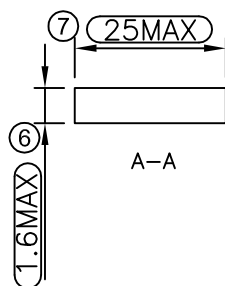
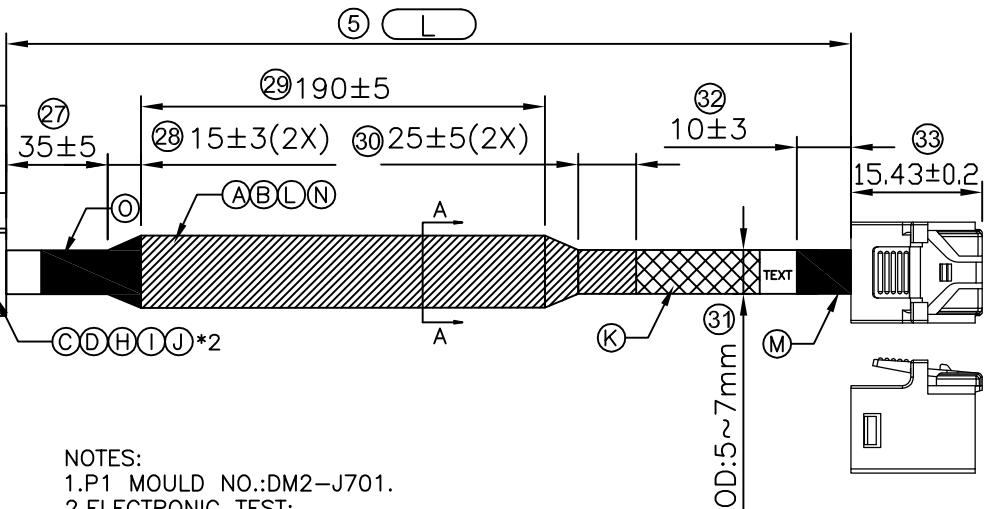

WIRING DIAGRAM

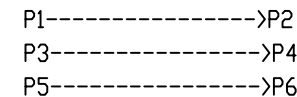

P1/P3/P5 P2/P4/P6

GND	D9	B9	GND
Tx 2-	D8	B8	Rx 2-
Tx 2+	D7	B7	Rx 2+
GND	D6	B6	GND
Tx 0-	D5	B5	Rx 0-
Tx 0+	D4	B4	Rx 0+
GND	D3	B3	GND
SIDEBAND 6	D2	D1	SIDEBAND 6
SIDEBAND 5	D1	D2	SIDEBAND 5
SIDEBAND 4	C1	C2	SIDEBAND 4
SIDEBAND 2	C2	C1	SIDEBAND 2
GND	C3	A3	GND
Tx 1+	C4	A4	Rx 1+
Tx 1-	C5	A5	Rx 1-
GND	C6	A6	GND
Tx 3+	C7	A7	Rx 3+
Tx 3-	C8	A8	Rx 3-
GND	C9	A9	GND
GND	B9	D9	GND
Rx 2-	B8	D8	Tx 2-
Rx 2+	B7	D7	Tx 2+
GND	B6	D6	GND
Rx 0-	B5	D5	Tx 0-
Rx 0+	B4	D4	Tx 0+
GND	B3	D3	GND
SIDEBAND 1	B2	B1	SIDEBAND 1
SIDEBAND 3	B1	B2	SIDEBAND 3
SIDEBAND 7	A1	A2	SIDEBAND 7
SIDEBAND 0	A2	A1	SIDEBAND 0
GND	A3	C3	GND
Rx 1+	A4	C4	Tx 1+
Rx 1-	A5	C5	Tx 1-
GND	A6	C6	GND
Rx 3+	A7	C7	Tx 3+
Rx 3-	A8	C8	Tx 3-
GND	A9	C9	GND

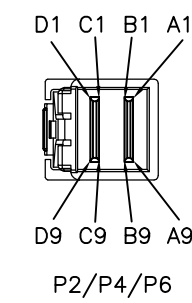

P2/P4/P6

UNLESS OTHERWISE SPECIFIED TOLERANCE
 ANG. ±3°
 .0 ±0.30
 .00 ±0.20

SCALE: AS SHOWN UNIT: mm

For SIP

DRAWN RILEY 04/18/2019 DRAWN NAME: HD MINI SAS 36P/HD MINI SAS 36P Cable 2/2

CHECKED / / PRODUCT NO. C10C213B05E01

APPROVED / / FILE NAME: C10C213B05E01(25)

REV. SIZE A4 REV. X8

CHANT SINCERE CO., LTD
 TEL: 886-02-86471251 FAX: 886-02-86472962