

HF
compliant



SPECIFICATION

MATERIAL AND FINISH:

1. DIELECTRIC: LCP
2. HOUSING: PA4T
3. CENTER CONTACTS: BRASS
CONTACT AREA: 80~160u" AG
SOLDER TAILS: 80~160u" SN(MATTE)
UNDERPLATE: 80~160u" NI
4. OUTER CONTACT (INTERFACE): STAINLESS STEEL
PLATING: 40~120u" SN(MATTE) OVER 40~120u" NI
5. OUTER CONTACT (PCB): ZAMAK
PLATING: 80~200u" SN(MATTE) OVER 120~240u"NI OVER 600~800u" CU
6. OUTER CONTACT (SHEET): ZAMAK
PLATING: 80~200u" SN(MATTE) OVER 120~200u"NI OVER 600~800u" CU

ELECTRICAL CHARACTERISTIC:

1. IMPEDANCE: 50 Ω
2. FREQUENCY: DC TO 9 GHz
3. INSULATION RESISTANCE: ≥1000 MΩ
4. CENTER CONTACT RESISTANCE: ≤15 mΩ
5. OUTER CONTACT RESISTANCE: ≤7.5 mΩ
6. TEST VOLTAGE: 500 Vrms
7. WORKING VOLTAGE: ≤60 V DC
8. POWER CURRENT: ≤1 A DC

MECHANICAL CHARACTERISTIC:

1. MATING CYCLES: ≥ 25 CYCLES
2. ENGAGEMENT FORCE: ≤ 75 N
3. DISENGAGEMENT FORCE WITH LOCK ENABLED: ≥110 N
4. DISENGAGEMENT FORCE WITH LOCK DISABLED: 5~60 N

ENVIRONMENT:

1. TEMPERATURE RANGE: -40°C TO +105°C

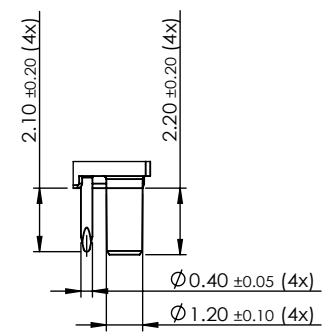
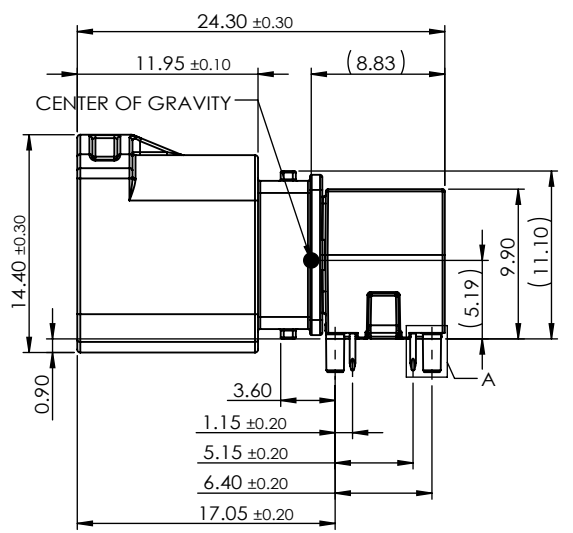
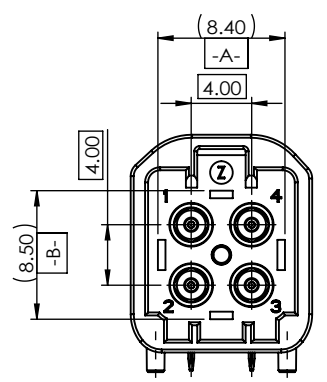
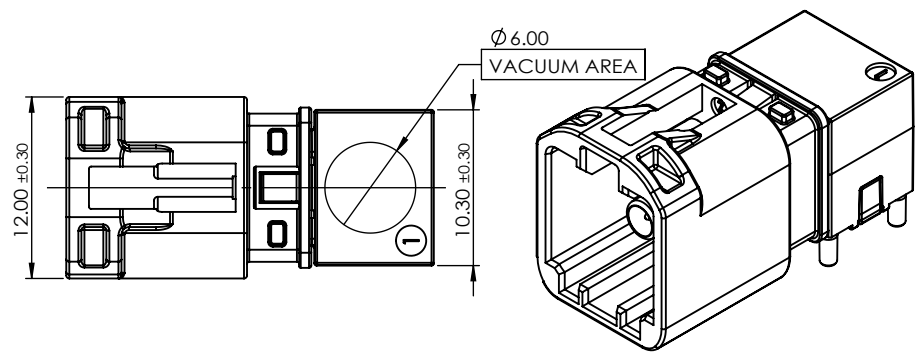

DETAIL A

DATE CODE: YYMM
YEAR
EX.18=2018
MONTH CODE

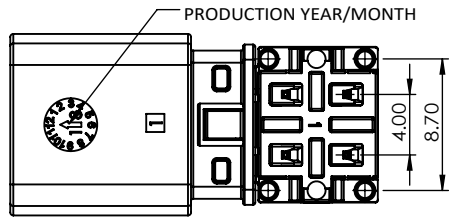

X=CODING(SEE PAGE 3/3)

4	5422601004X	N/A	6 O'CLOCK	RoHS+HF
3	5422601003X	N/A	12 O'CLOCK	RoHS+HF
2	5422601002X	410AF04CFTB2T3CX	6 O'CLOCK	RoHS
1	5422601001X	410AF04CFTB2T1CX	12 O'CLOCK	RoHS
ITEM	NEW P/N.	OLD P/N.	CODING NOSE	NOTE

UNLESS OTHERWISE SPECIFIED TOLERANCE		SIP
ANG.	±5°	Crnk Cpk
0.	±0.50	
.0	±0.30	
.00	±0.20	



	I	ECN-2509064(CHICHI)SEE PAGE 2/3	15SEP2025	DRAWN: HOLLY_TU	16 Sep 2025	TITLE:		
C6, G1	H	ECN-2508031(JOAN)ADD P/N & MODIFY GREEN MARK & SEE PAGE 2/3-3/3	07AUG2025	CHECKED: JERRY_CHOU	16 Sep 2025	MINI FAKRA 4PIN R/A PLUG (BM TYPE)		
	G	ECN-2412023(QUEENIE)SEE PAGE 2/3	09DEC2024	APPROVED: JERRY_CHOU	23 Sep 2025	PART NO.	5422601XXXX	C
ZONE	REVISION	DESCRIPTION	DATE	SIZE A4	SHEET 1/3	REV. I	CODE: GC	CUSTOMER:

HF
compliant



● SOLDER AREA

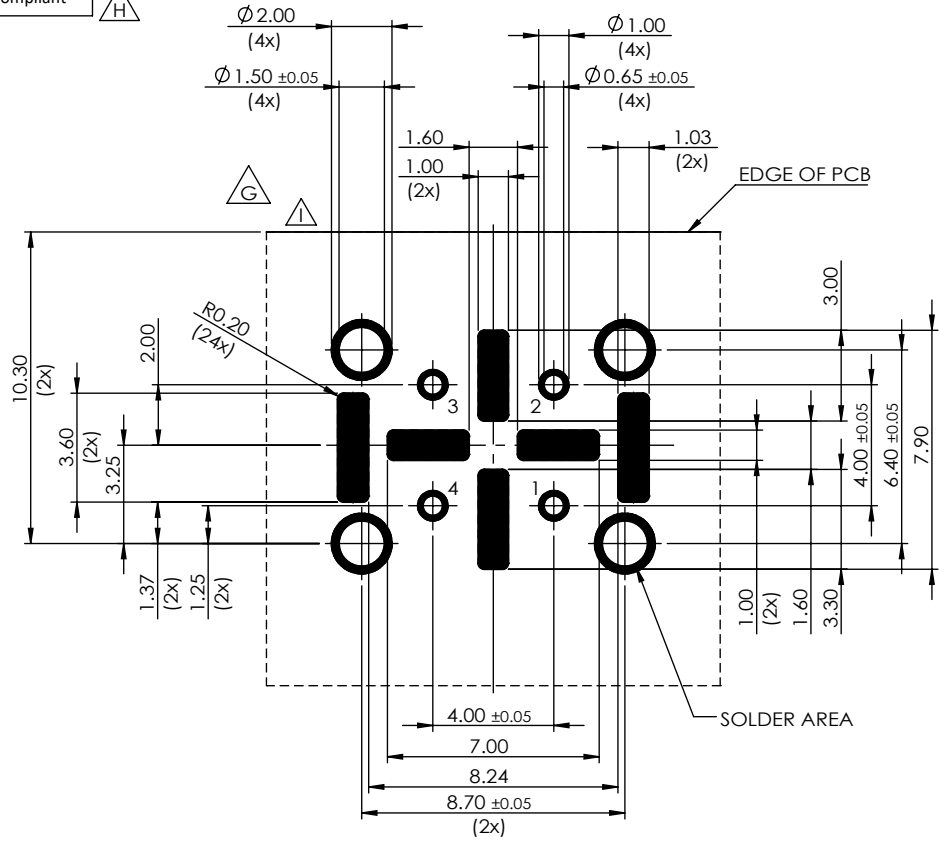

RECOMMENDED P.C.B LAYOUT
TOLERANCES: ±0.10mm

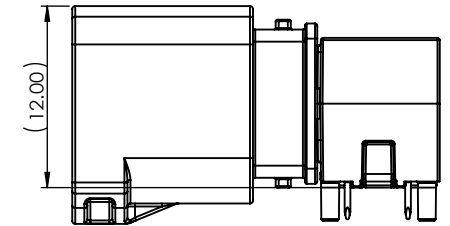
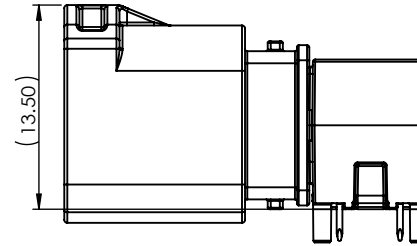
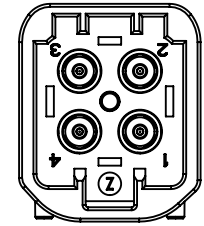
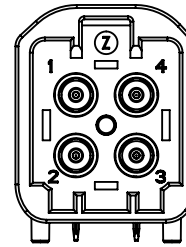

12 O'CLOCK

6 O'CLOCK

UNLESS OTHERWISE SPECIFIED TOLERANCE	
ANG.	±5°
0.	±0.50
.0	±0.30
.00	±0.20

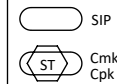

SCALE:	AS SHOWN	UNIT:	mm
--------	----------	-------	----

F2	I	ECN-2509064(CHICHI)ADD PIN ASSIGNMENT	15SEP2025
G1	H	ECN-2508031(JOAN)MODIFY GREEN MARK & SEE PAGE 1/3 & 3/3	07AUG2025
F2	G	ECN-2412023(queenie)Increase solder area	09DEC2024
Zone	Revision	Description	Date

DRAWN:	HOLLY_TU	16 Sep 2025
CHECKED:	JERRY_CHOU	16 Sep 2025
APPROVED:	JERRY_CHOU	23 Sep 2025
SIZE	A4	SHEET 2/3
REV.	I	

TITLE:		MINI FAKRA 4PIN R/A PLUG (BM TYPE)
PART NO.	5422601XXXX	
CODE:	GC	CUSTOMER:

HF
compliant



CODINGS 1:1

CODING	A	B	C	D	E	F
PLUG						
COLOR	BLACK	WHITE	BLUE	CLARET VIOLET	GREEN	BROWN
RAL	SIM. 9005	SIM. 9010	SIM. 5012	SIM. 4004	SIM. 6017	SIM. 8011
CODING	Z					
PLUG						
COLOR	WATER BLUE					
RAL	SIM. 5021					

UNLESS OTHERWISE SPECIFIED TOLERANCE	SIP	 CHANT SINCERE CO.,LTD
ANG. ±5° 0. ±0.50 .0 ±0.30 .00 ±0.20	Crnk Cpk	
SCALE: AS SHOWN	UNIT: mm	
DRAWN: HOLLY_TU	16 Sep 2025	TITLE: MINI FAKRA 4PIN R/A PLUG (BM TYPE)
CHECKED: JERRY_CHOU	16 Sep 2025	PART NO. 5422601XXXX
APPROVED: JERRY_CHOU	23 Sep 2025	CODE: GC
SIZE A4	SHEET 3/3	CUSTOMER:

ZONE	REVISION	DESCRIPTION	DATE
	I	ECN-2509064(CHICHI)SEE PAGE 2/3	15SEP2025
G1	H	ECN-2508031(JOAN)MODIFY GREEN MARK &SEE PAGE 1/3&2/3	07AUG2025
	G	ECN-2412023(QUEENIE)SEE PAGE 2/3	09DEC2024