

RoHS
compliant

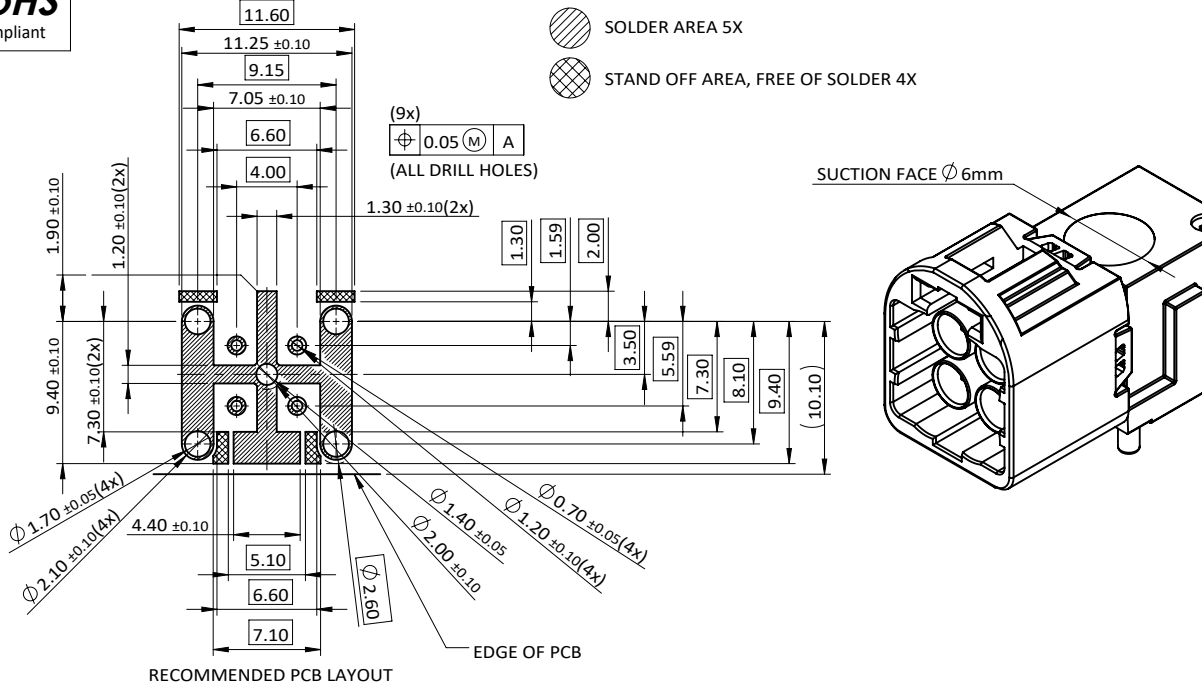

SOLDER AREA 5X
 STAND OFF AREA, FREE OF SOLDER 4X

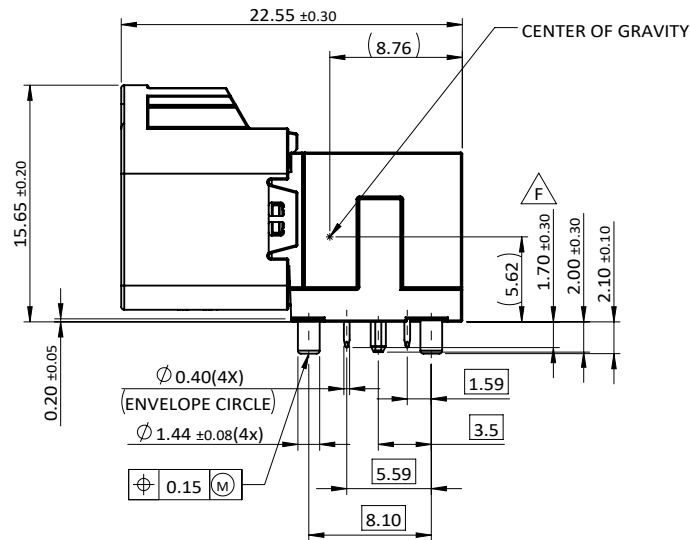
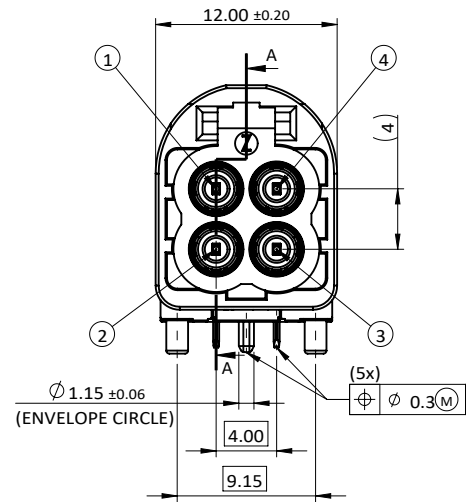
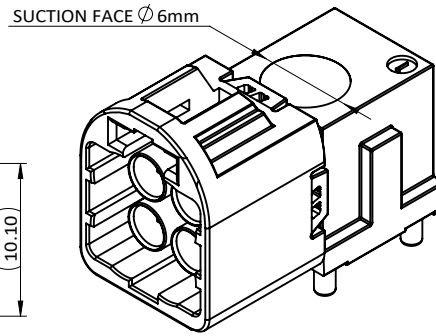

MATERIAL

1. DIELECTRIC: LCP
2. HOUSING: PA
3. CENTER CONTACTS: BRASS
4. OUTER CONTACT (INTERFACE): STAINLESS STEEL
5. OUTER CONTACT (PCB): ZAMAK
6. OUTER CONTACT (SHEET): BRASS

PLATING

1. CENTER CONTACT: CONTACT AREA: 6~30u" Au
SOLDER TAILS: 80u"~160u" Sn (MATTE)
UNDERPLATE: 80u"~160u" Ni
2. OUTER CONTACT (INTERFACE):
120u"~240u" Sn (MATTE) OVER 40u"~120u" Ni
3. OUTER CONTACT (PCB): 80u"~200u" Sn (MATTE) PLATED OVER
120u"~240u" Ni PLATED OVER
600u"~800u" Cu UNDERPLATED
4. OUTER CONTACT (SHEET): 80u"~160u" Sn (MATTE) PLATED OVER
80u"~160u" Ni PLATED OVER

ELECTRICAL

1. IMPEDANCE: 50 Ω
2. FREQUENCY: DC TO 9GHz
3. INSULATION RESISTANCE: ≥1000 MΩ
4. CENTER CONTACT RESISTANCE: ≤15 MΩ
5. OUTER CONTACT RESISTANCE: ≤7.5 MΩ
6. TEST VOLTAGE: 800Vrms
7. WORKING VOLTAGE: ≤60 V DC
8. POWER CURRENT: ≤1 A DC

ENVIRONMENTAL

1. TEMPERATURE RANGE: -40°C TO +105°C

MECHANICAL

1. MATING CYCLES: ≥ 25 CYCLES
2. ENGAGEMENT FORCE: ≤45 N
3. DISENGAGEMENT FORCE: ≥5 N
4. RETENTION FORCE LATCH: ≥110 N
5. CODING EFFICIENCY: ≥150 N

X=CODING(SEE PAGE 3/3)

ITEM	NEW P/N	OLD P/N	CONTACT AREA	ORIENTATION	PACKING
5	5420102005X	410AF04CDBT3T2CX	30u" Au	9 O'CLOCK	TAPE & REEL
4	5420102004X	410AF04C6TB3T4CX	6u" Au	3 O'CLOCK	TAPE & REEL
3	5420102003X	410AF04C6TB3T3CX	6u" Au	6 O'CLOCK	TAPE & REEL
2	5420102002X	410AF04C6TB3T2CX	6u" Au	9 O'CLOCK	TAPE & REEL
1	5420102001X	410AF04C6TB3T1CX	6u" Au	12 O'CLOCK	TAPE & REEL

UNLESS OTHERWISE SPECIFIED TOLERANCE ANG. ±5° 0. ±0.50 .0 ±0.30 .00 ±0.20	SIP	 CHANT SINCERE CO., LTD
	Crmk Cpk	
SCALE: 2:1	UNIT: mm	

ZONE	REVISION	DESCRIPTION	DATE	DRAWN:	CHECKED:	APPROVED:	REV.	CODE:	CUSTOMER:
F7	H	ECN-2406069(JASON)CHANGE PLATING SPECIFICATIONS	20JUN2024	KEVIN_ZHENG	JERRY_CHOU	JERRY_CHOU	H	GC	
	G	ECN-2401116(BENSON)SEE PAGE 3/3	31JAN2024						
	F	ECN-2310043(TERESA)MODIFY DIMENSION	18OCT2023						
		TITLE: MINI FAKRA R/A PLUG-AM TYPE		PART NO. 5420102XXXX					
		SCALE: 2:1		UNIT: mm					



RoHS
compliant



CODING DIRECTION INFORMATION

5420102001X
12 O'CLOCK

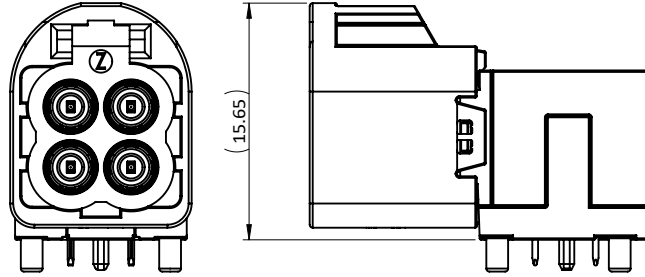

5420102002X
9 O'CLOCK

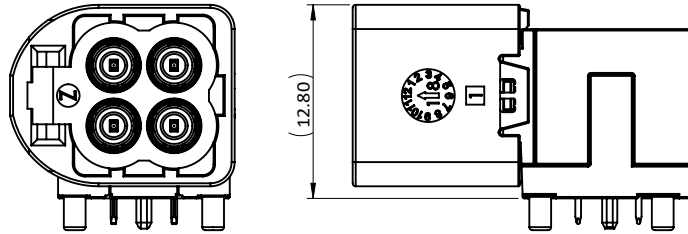

5420102003X
6 O'CLOCK

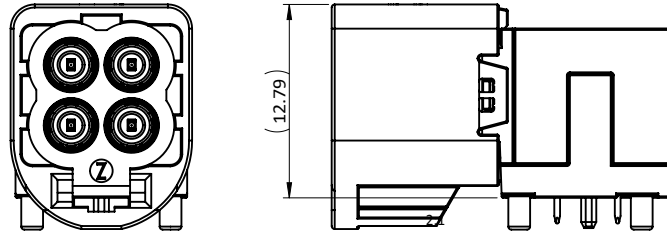

5420102004X
3 O'CLOCK

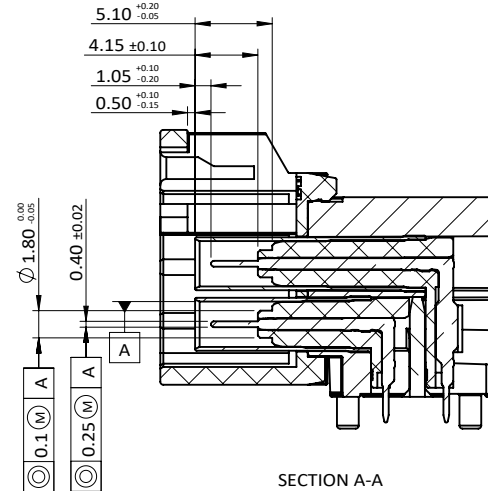
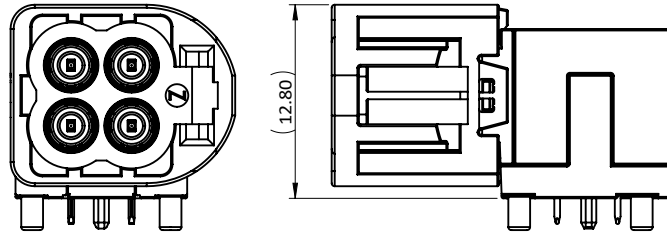

UNLESS OTHERWISE SPECIFIED TOLERANCE		SIP Crnk Cpk		 CHANT SINCERE CO.,LTD	
ANG. ±5° 0. ±0.50 .0 ±0.30 .00 ±0.20					
SCALE:	2:1	UNIT:	mm	TITLE:	
DRAWN:	KEVIN_ZHENG	05 JUL 2024	MINI FAKRA R/A PLUG-AM TYPE		
CHECKED:	JERRY_CHOU	05 JUL 2024	PART NO.		5420102XXXX
APPROVED:	JERRY_CHOU	05 JUL 2024	REV.	H	CUSTOMER:
		SIZE	A4	SHEET	2/3
ZONE		REVISION	DESCRIPTION		DATE

H	ECN-2406069(JASON)SEE PAGE 1/3	20JUN2024
G	ECN-2401116(BENSON)SEE PAGE 3/3	31JAN2024
F	ECN-2310043(TERESA)SEE PAGE 1/3	18OCT2023

RoHS
compliant



A	B	C	D	E	F	G
JET BLACK SIMILAR RAL 9005	PURE WHITE SIMILAR RAL 9010	LIGHT BLUE SIMILAR RAL 5012	CLARET VIOLET SIMILAR RAL 4004	MAY GREEN SIMILAR RAL 6017	NUT BROWN SIMILAR RAL 8011	PLATINUM GREY SIMILAR RAL 7036
Z						
WATER BLUE SIMILAR RAL 5021						

UNLESS OTHERWISE SPECIFIED TOLERANCE		SIP Crk Cpk		 CHANT SINCERE CO.,LTD	
ANG.	±5°	SCALE:	2:1		UNIT:
0.	±0.50	DRAWN:	KEVIN_ZHENG	REV.	05 JUL 2024
.0	±0.30	CHECKED:	JERRY_CHOU	REV.	05 JUL 2024
.00	±0.20	APPROVED:	JERRY_CHOU	REV.	H
		SIZE	A4	SHEET	3/3
		TITLE:		MINI FAKRA R/A PLUG-AM TYPE	
		PART NO.		5420102XXXX	
		CODE:		GC	
		CUSTOMER:			

H	ECN-2406069(JASON)SEE PAGE 1/3	20JUN2024
G	ECN-2401116(BENSON)MODIFY TABLE CONTENT	31JAN2024
F	ECN-2310043(TERESA)SEE PAGE 1/3	18OCT2023
ZONE	REVISION	DESCRIPTION
1	2	3

1 2 3 4 5 6 7 8 9 10

G

F

E

D

C

B

A

1 2 3 4 5 6 7 8 9 10