



RoHS
compliant

SPECIFICATION

MATERIAL AND FINISH:

- CODING HOUSING: PA, COLOR SEE DETAIL
- INNER HOUSING: LCP, COLOR BLACK
- CONTACT: BRASS
PLATING: CONTACT AREA: 6u" AU
SOLDER AREA: 80~160u" SN (MATTE) 
UNDERPLATE: 80~160u" NI
- OUTER CONTACT(INTERFACE): STAINLESS STEEL
PLATING: 120~240u" SN (MATTE) OVER 
40u"~120u" NI PLATED OVERALL
- OUTER CONTACT(PCB): ZAMAK
PLATING: 80~200u" SN (MATTE) PLATED OVER 
120~240u" NI PLATED OVER
600~800u" CU UNDERPLATED OVERALL

ELECTRICAL CHARACTERISTIC:

- IMPEDANCE: 50 Ω
- FREQUENCY: DC TO 9 GHz
- INSULATION RESISTANCE: ≥1X10³ MΩ
- CENTER CONTACT RESISTANCE: ≤15 mΩ
- OUTER CONTACT RESISTANCE: ≤5 mΩ
- TEST VOLTAGE: ≤ 800 Vrms
- WORKING VOLTAGE: ≤ 60 V DC
- POWER CURRENT: ≤ 1 A DC

MECHANICAL CHARACTERISTIC:

- MATING CYCLES: ≥25
- ENGAGEMENT FORCE: ≤15 N
- DISENGAGEMENT FORCE: ≥2 N
- RETENTION FORCE LATCH: ≥110 N
- CODING EFFICIENCY: ≥150 N

ENVIRONMENT:

- TEMPERATURE RANGE: -40°C TO +105°C

NOTE:

- WEIGHT: 3.4g

STAND OFF AREA, FREE OF SOLDER

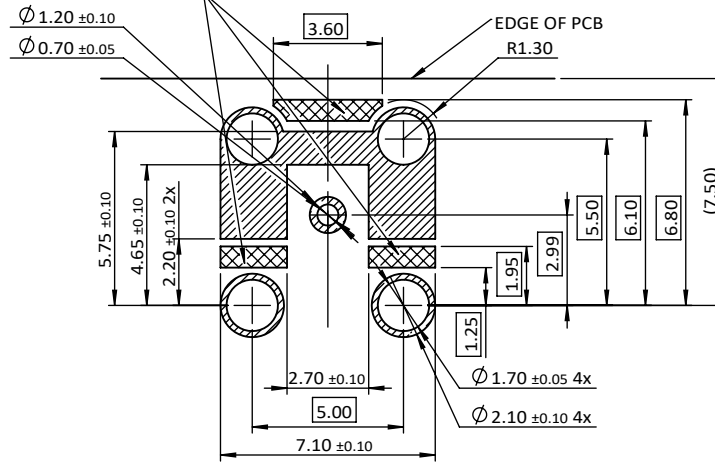

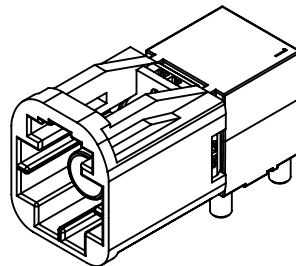
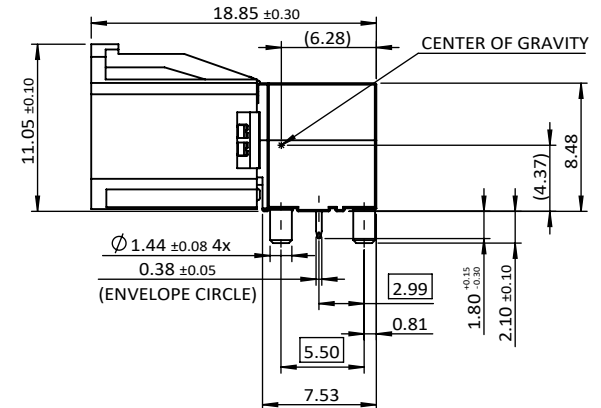
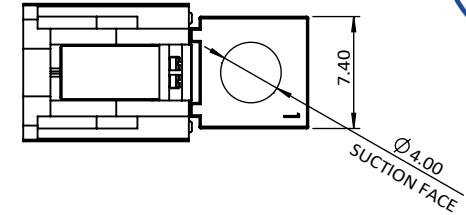
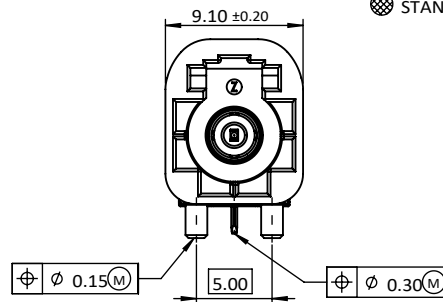

RECOMMENDED PCB LAYOUT  SOLDER AREA 4x

 STAND OFF AREA, FREE OF SOLDER 3x

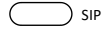

LAST DIGITAL OF PART NUMBER X= CODING KEY,SEE PAGE 3/3

5420101004X	410AF01C6TB3T4CX	3 O'CLOCK	TAPE & REEL
5420101003X	410AF01C6TB3T3CX	6 O'CLOCK	TAPE & REEL
5420101002X	410AF01C6TB3T2CX	9 O'CLOCK	TAPE & REEL
5420101001X	410AF01C6TB3T1CX	12 O'CLOCK	TAPE & REEL

NEW P/N	OLD P/N	CODING NOSE	PACKING
UNLESS OTHERWISE SPECIFIED TOLERANCE		 CHANT SINCERE CO.,LTD	
ANG.	±5°		
0.	±0.50		
.0	±0.30		
.00	±0.20		
SCALE: 4:1	UNIT: mm	 SIP  Crmk Cpk	

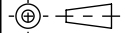
F3	G	ECN-2602043(JOE)REVISE PLATING SPECIFICATION	11FEB2026	DRAWN: HOLLY_TU	13 FEB 2026	TITLE: MINI FAKRA AM 1X1		
C1	F	ECN-2509063(LITING)ADD WEIGHT	15SEP2025	CHECKED: JERRY_CHOU	23 FEB 2026			
F2, F3	E	ECN-2408089(JOE)CHANGE PLATING SPECIFICATIONS	23AUG2024	APPROVED: JERRY_CHOU	23 FEB 2026	PART NO. 5420101XXXX		
ZONE	REVISION	DESCRIPTION	DATE	 SIZE A4	SHEET 1/3	REV. G	CODE: GC	CUSTOMER:



RoHS
compliant



CODING DIRECTION INFORMATION

5420101001X
12 O'CLOCK

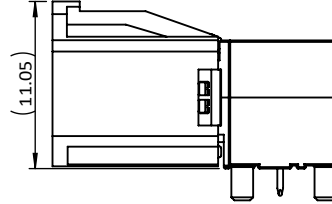
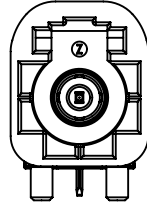

5420101002X
9 O'CLOCK

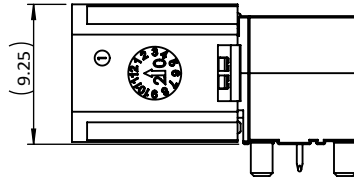
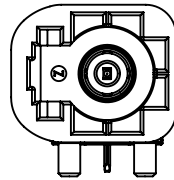

5420101003X
6 O'CLOCK

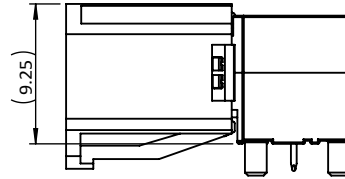

5420101004X
3 O'CLOCK

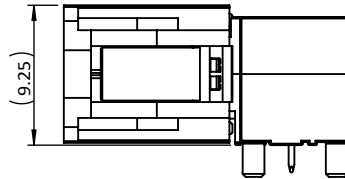
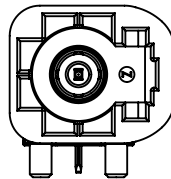

UNLESS OTHERWISE SPECIFIED TOLERANCE		SIP
ANG.	±5°	Crmk Cpk
0.	±0.50	
.0	±0.30	
.00	±0.20	



SCALE:	AS SHOWN	UNIT:	mm
DRAWN:	HOLLY_TU	13 Feb 2026	TITLE:
CHECKED:	JERRY_CHOU	23 Feb 2026	MINI FAKRA AM 1x1
APPROVED:	JERRY_CHOU	23 Feb 2026	PART NO. 5420101XXXX

REV. G	CODE: GC	CUSTOMER:
--------	----------	-----------

ZONE	REVISION	DESCRIPTION	DATE
1	2	3	4
1	G	ECN-2602043(JOE)SEE PAGE 1/3	11FEB2026
1	F	ECN-2509063(LITING)SEE PAGE 1/3	15SEP2025

	SIZE A4	SHEET 2/3
--	---------	-----------

RoHS
compliant



*=DEVELOPING

	A	B	*C	*D	*E	F	*G	*H	*J	*K	*N	Z
	BLACK SIM.9005	WHITE SIM. 9010	BLUE SIM. 5012	CLARET VIOLET SIM. 4004	GREEN SIM. 6017	BROWN SIM. 8011	GREY SIM. 7036	LIGHT PINK SIM. 3015	BEIGE SIM. 1001	CURRY SIM. 1027	PASTEL GREEN SIM. 6019	WATER BLUE SIM. 5021



UNLESS OTHERWISE SPECIFIED TOLERANCE		SIP Crnk Cpk		 CHANT SINCERE CO.,LTD				
ANG.	±5°	0.	±0.50			SCALE:	AS SHOWN	UNIT:
.0	±0.30	.00	±0.20	DRAWN:	HOLLY_TU	13 Feb 2026	TITLE:	MINI FAKRA-AM 1X1 CODING HOUSING
				CHECKED:	JERRY_CHOU	23 Feb 2026	PART NO.	5420101XXXX
				APPROVED:	JERRY_CHOU	23 Feb 2026	CODE:	GC
				SIZE	A4	SHEET	3/3	CUSTOMER:

	G	ECN-2602043(JOE)SEE PAGE 1/3	11FEB2026
	F	ECN-2509063(LITING)SEE PAGE 1/3	15SEP2025
	E	ECN-2408089(JOE)SEE PAGE 1/3	23AUG2024
ZONE	REVISION	DESCRIPTION	DATE
1	2	3	4