

SPECIFICATION
MATERIAL
 Insulator: Thermal Plastic UL94HB
 Contacts: Copper alloy
 Shell: SPCC
CONTACT PLATING
 Underplate: 50u"~100u" Nickel
 Contact area: 1~3u"gold or 30u"Pd-Ni+2u"gold
 Solder tails area: 100u"~200u" Tin(Lead Free)
 Part no.

377 A H 09 F X T S4 N X C X
 1 2 3 4 5 6 7 8 9 10 11 12

- | | |
|---|--|
| 1.SERIES NO.
377=USB Series 3.0 | 7.SOLDER TAILS AREA PLATING:
T=100u"~200u" TIN |
| 2.TYPE:
A=STANDARD | 8.APPLY TYPE:
S4=Reverse DIP TYPE |
| 3.GREEN OPTION:
H=RoHS(Matte-Halogen Free) | 9.SHELL PLATING:
N=Nickel |
| 4.CONTACT NUMBER:
09 PIN | 10.CENTER HEIGHT OPTION:
Z=off-set 1.75mm, W/O Mylar
For SHELL STEEL (魚叉脚10) |
| 5.CONTACT TYPE:
F=FEMALE | 11.PACKING OPTION:
C=TAPE & REEL |
| 6.CONTACT AREA PLATING:
S=Gold Flash (Selective) | 12.INSULATOR COLOR:
2=BLUE(Pantone 300C) |

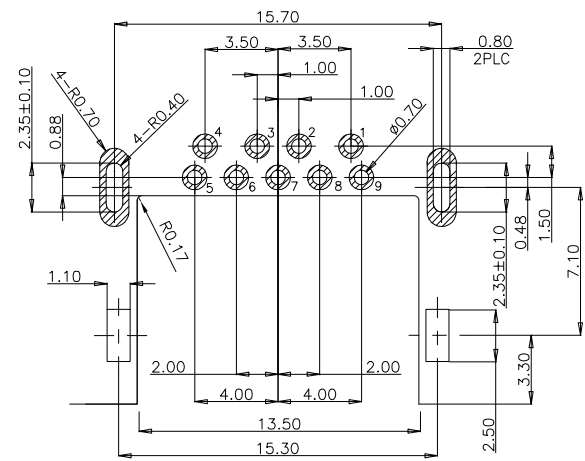
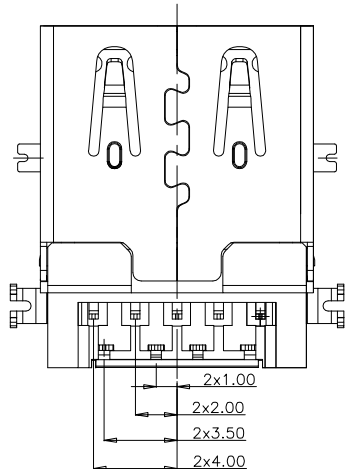
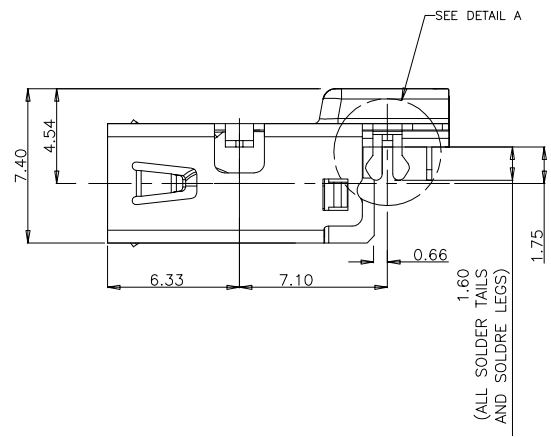
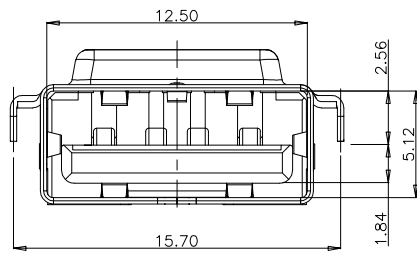
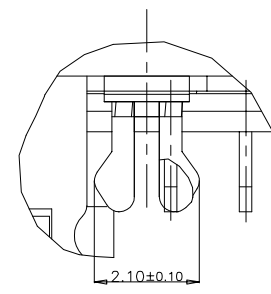
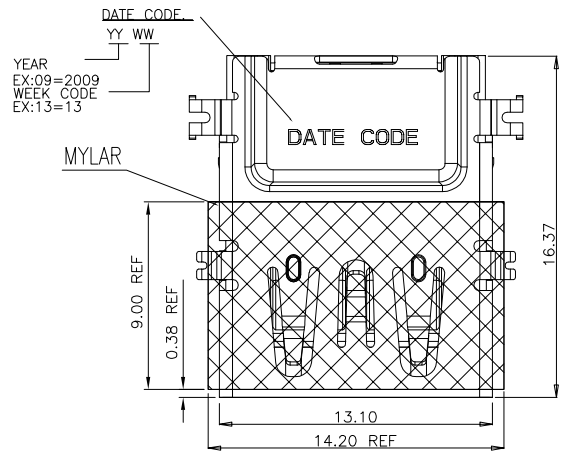

RECOMMENDED P.C.B LAYOUT
 TOLERANCES: ±0.05mm

UNLESS OTHERWISE SPECIFIED TOLERANCE	
ANG.	±5°
0.	±0.50
.0	±0.30
.00	±0.20



CHANT SINCERE CO.,LTD
 TEL:886-02-86471251 FAX:886-02-86472962

SCALE: AS SHOWN	UNIT: mm
DRAWN PEARL	04/02/2014
CHECKED	/ /
APPROVED	/ /

DRAWN NAME:
 USB 3.0 Reverse Type off-set 1.75mm
 (Length=17.07mm)

PRODUCT NO. 317AH09FXTS4NVCX

REV.	DESCRIPTION	DATE	SIZE	REV.	FILE NAME:
1			A4	A	C-317AH09FXTS4NVCX(S06)