

**SPECIFICATION**  
**MATERIAL**  
 Insulator: PBT(F202G15)  
 Contacts: Copper Alloy  
 Shell: Steel  
 O-ring: Materials: Silicone(TOSHIBA 221-5U)  
 Sealant: Epoxy-Resin  
 Rivet: Copper Alloy

**CONTACT PLATING**  
 Underplate :50u"~150u" Nickel  
 Contact Area :1u"~30u" Selective Gold  
 Rivet :50u"~100u" Nickel

**ELECTRICAL**  
 Operation Voltage :250 VAC Max  
 Current Rating :3 Amps Max  
 Contact Resistance :15 Mohms Min 500 VDA  
 Dielectric Withstanding Voltage 1000 VAC/Minute  
 Temperature Range :-55 °C TO +105 °C  
 Degree of Protection :IP67(IEC60529)  
 PART NO.

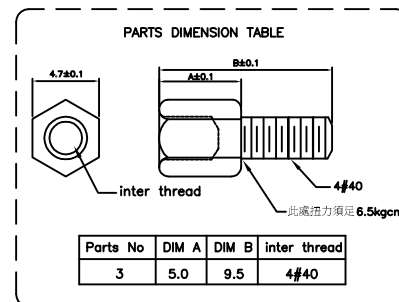
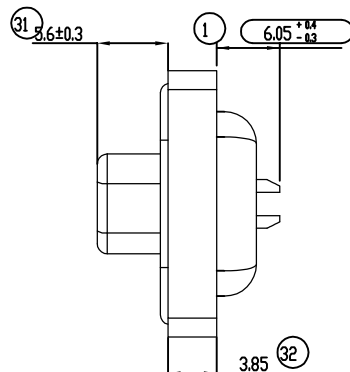
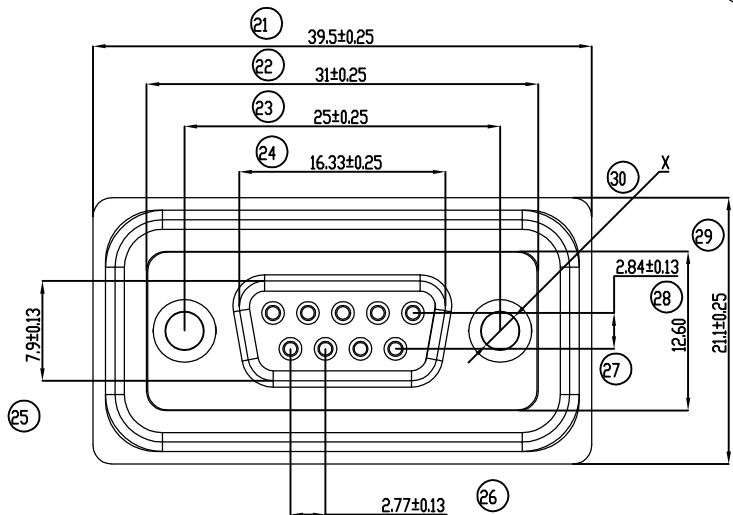

249 A E X X F S S A I N X A 3  
 1 2 3 4 5 6 7 8 9 10 11 12

- 1.SERIES NO.
- 2.TYPE
- 3.GREEN OPTION:
- 4.CONTACT NUMBER:
- 5.CONTACT TYPE:
- 6.PLATED ON THE CONTACT SIDE:
- 7.PLATED ON THE SOLDERING SIDE:
- 8.TYPE:
- 9.SHELL PLATING:
- 10.PROCESS OPTION
- 11.PACKING:
- 12.INSULATOR COLOR:

PIN	A	B	C	D	X	Y
9	39.50	31.00	25.00	16.30	25.20	20
15	48.00	39.30	33.32	24.60	33.50	28.30
25	61.50	53.20	47.04	38.30	47.20	42.00
37	77.80	69.50	63.50	54.80	63.70	58.50

For SIP  
 For CrK/Cpk

UNLESS OTHERWISE SPECIFIED TOLERANCE	
ANG.	± 2°
0.	± 0.30
.0	± 0.20
.00	± 0.10

CHANT SINCERE CO.,LTD  
 TEL:886-02-86471251 FAX:886-02-86472962

SCALE: AS SHOWN UNIT: mm  
 DRAWN PEARL 11/16/2016  
 CHECKED  
 APPROVED

PRODUCT NO. 249AEXXSSA1NXA3  
 FILE NAME: C-249AEXXSSA1NXA3

REV.	DESCRIPTION	DATE	SIZE	REV.
1			A4	G