

NOTES:  
 MATERIAL:  
 CAGE: COPPER ALLOY THICKNESS 0.25mm  
 CONNECTOR:  
 PLASTIC HOUSING: HIGH TEMPERATURE LCP, UL94 V-0.  
 SPRING: STAINLESS STEEL, THICKNESS 0.20mm  
 CONTACTS: PHOSPHOR BRONZE, THICKNESS 0.20mm  
 PLATING: 15μ" MIN. GOLD ON MATING AREA,  
 150μ" MIN. MATE TIN ON SOLDER TAILS.

PACKAGING: TRAY PACKAGING.  
 OPERATING TEMPERATURE: -40°C TO +105°C  
 STORAGE TEMPERATURE: -55°C TO +105°C

PART NUMBER:  
 902 G H B1 B C T AA X 3 A 3  
 1 2 3 4 5 6 7 8 9 10 11 12

- |                              |                               |
|------------------------------|-------------------------------|
| 1.SERIES NO.                 | 9.SHELL PLATING:              |
| 2.TYPE: G=PressFit           | 0=Non Plating/Spring          |
| 3.GREEN OPTION:              | N=Ni Plating(50u" Min)/Spring |
| H=RoHS+HF(Matte Plated)      | 10.PROCESS OPTION:            |
| 4.PORT NO:                   | 3=With Outer Light Pipe       |
| B1=2x1                       | 11.PACKAGE OPTION:            |
| 5.CONTACT TYPE:              | A=Tray                        |
| B=Female                     | 12.INSULATOR COLOR:           |
| 6.CONTACT PLATING:           | 3=BLACK                       |
| C=15u" Gold                  |                               |
| 7.SOLDER TAILS AREA PLATING: |                               |
| T=Tin plated                 |                               |
| 8.TYPE OPTION:               |                               |
| AA=SFP ASSEMBLY              |                               |
| (Non Grounding Pin)          |                               |

UNLESS OTHERWISE SPECIFIED TOLERANCE			
.X±0.20	.X±1°		
.XX±0.15	.XX±5°	<b>CHANT SINCERE CO.,LTD</b> TEL:886-02-86471251 FAX:886-02-86472362	
SCALE: AS SHOWN	UNIT: mm	DRAWN NAME: SFP ASSY.2X1	
DRAWN: RITA	01/29/2019	CHECKED: PRESS FIT, NON Grounding Pin 1/4	
CHECKED:		APPROVED:	
APPROVED:		PRODUCT NO. 902GHB2BCTAA3A3	
REV. 1	DESCRIPTION	DATE	SIZE A4 REV. A FILE NAME: 902GHB2BCTAA03A3(X07)

REV.	DESCRIPTION	DATE
1		
2		
3		
4		
5		
6		

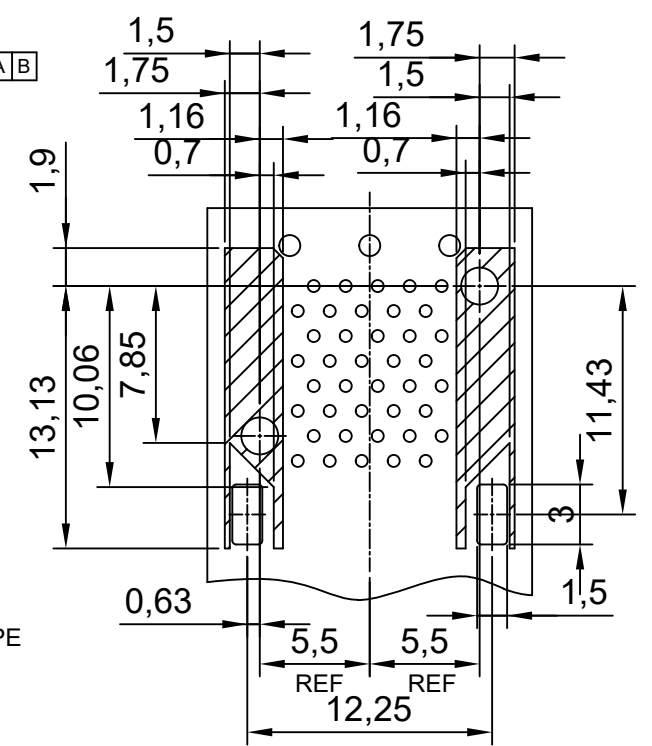
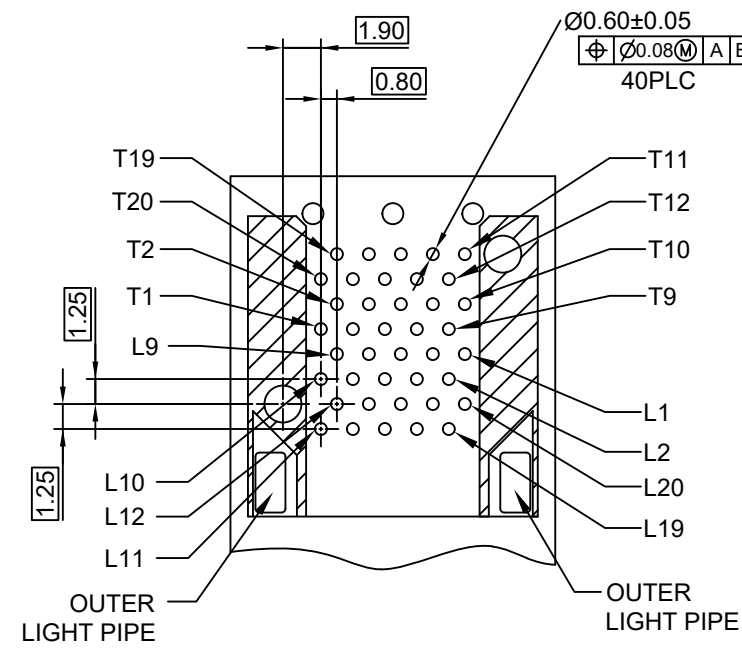
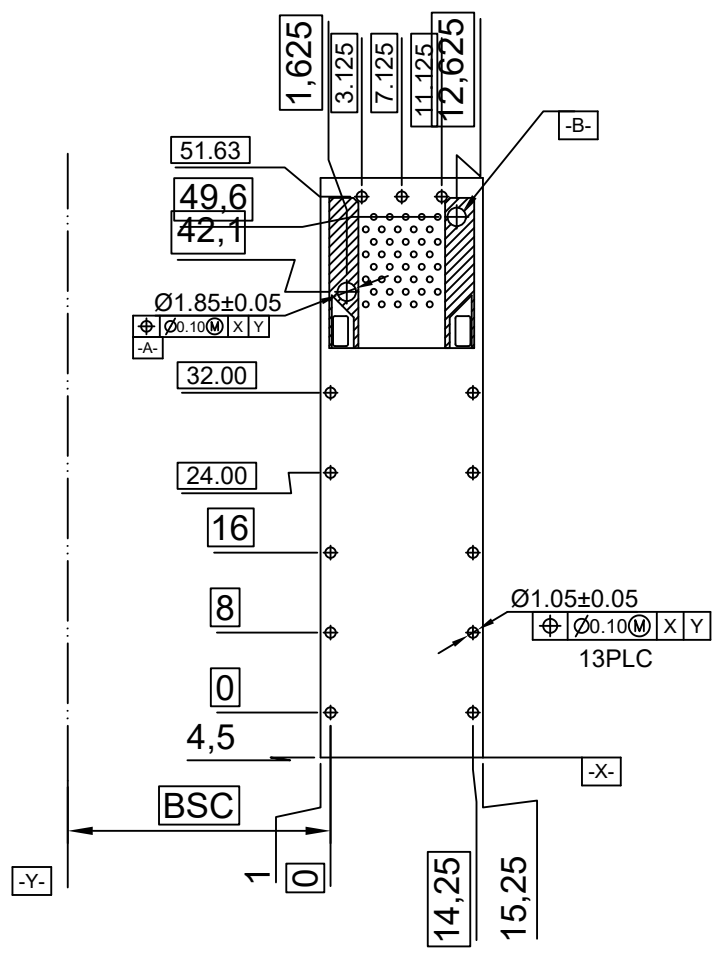

ECOMMENDED PCB CONFIGURATION

UNLESS OTHERWISE SPECIFIED TOLERANCE			
.X±0.20	.X±1°	CHANT SINCERE CO.,LTD	
.XX±0.15	.XX±5°	TEL:886-02-86471251 FAX:886-02-86472362	
.XXX±0.10		SCALE: AS SHOWN	UNIT: mm
SCALE: AS SHOWN	UNIT: mm	DRAWN: RITA	01/29/2019
DRAWN: RITA	01/29/2019	CHECKED:	
CHECKED:		APPROVED:	
APPROVED:		PRODUCT NO.	902GHB2BCTAAX3A3
PRODUCT NO.	902GHB2BCTAAX3A3	FILE NAME:	902GHB2BCTAA03A3(X07)
FILE NAME:	902GHB2BCTAA03A3(X07)		

REV.	DESCRIPTION	DATE	SIZE	REV.	FILE NAME
1			A4	A	

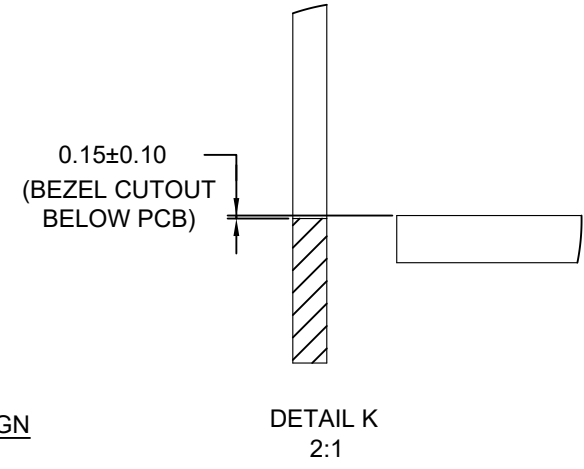
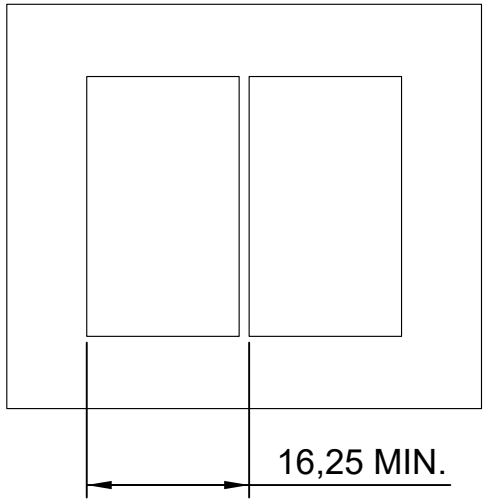
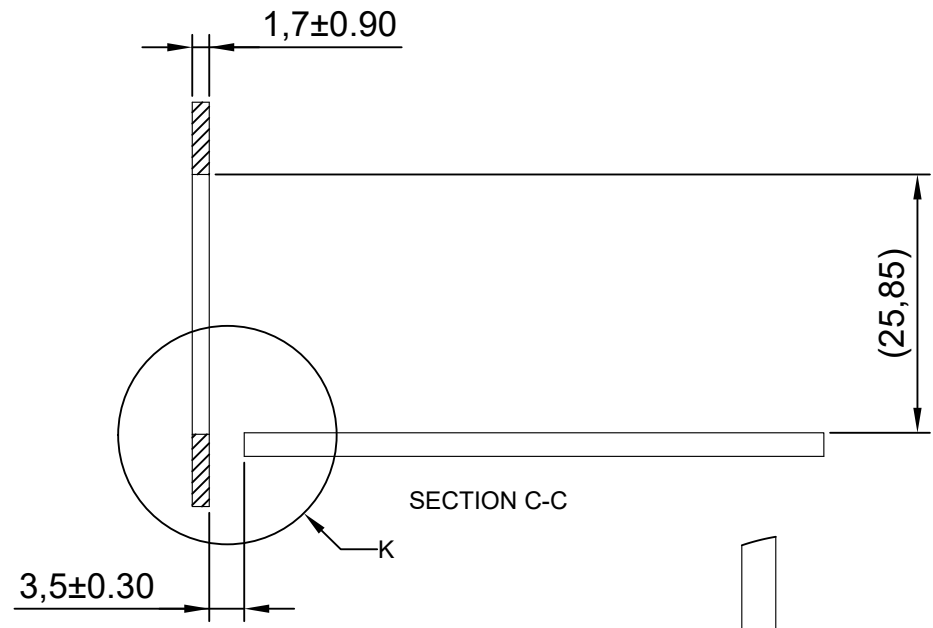
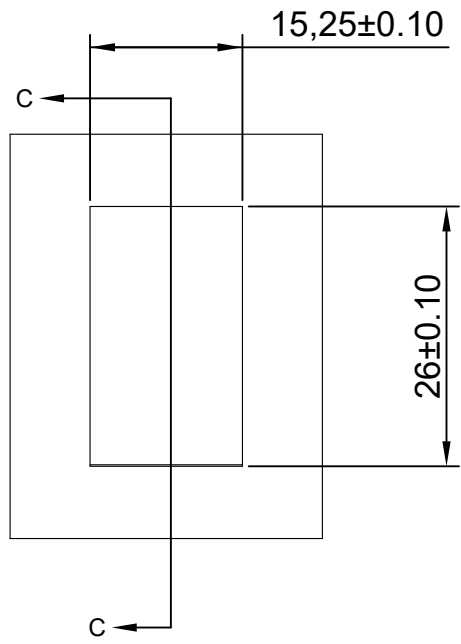

RECOMMENDED BEZEL DESIGN

DETAIL K  
2:1

UNLESS OTHERWISE SPECIFIED TOLERANCE

.X±0.20	.X±1°
.XX±0.15	.XX±5°
.XXX±0.10	



CHANT SINCERE CO.,LTD  
TEL 886-02-86471251 FAX 886-02-86472362

SCALE:	AS SHOWN	UNIT:	mm
DRAWN:	RITA	DATE:	01/29/2019
CHECKED:			
APPROVED:			

DRAWN NAME:	SFP ASSY.2X1
	PRESS FIT, NON Grounding Pin 3/4
PRODUCT NO.	902GHB2BCTAAX3A3
FILE NAME:	902GHB2BCTAA03A3(X07)

REV.	DESCRIPTION	DATE

SIZE	A4	REV.	A
------	----	------	---

# PACKAGE INFORMATION AND LABEL

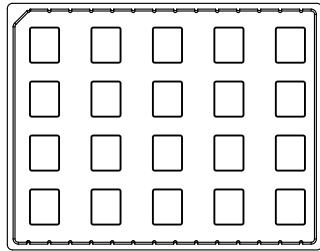

1. PRODUCTS IN TRAYS

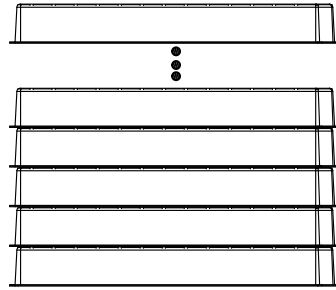

2. TRAYS OVERLAY:  
(THE NEXT TRAY NEED ROTATE 180 DEGREE AND PUT IT ON PREVIOUS TRAY.)  
(相邻两个吸塑间水平方向成180度摆放)

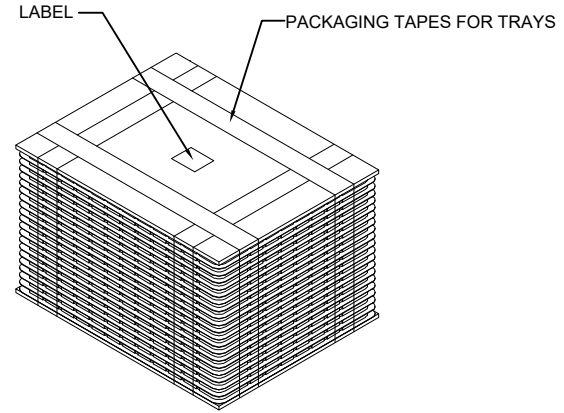

3. LABEL & PACKAGING TAPES FOR TRAYS:

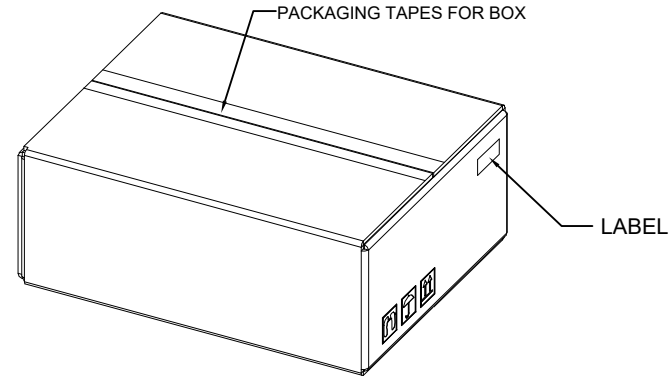

4. LABEL & PACKAGING TAPES FOR BOX

PACKAGING LISTS	
ITEM	Q'TY
PRODUCT	180 PCS
TRAY	9 PCS
BOX(L340*W265*H200MM)	1 PCS
LABLE	2 PCS
PACKAGING TAPES	8 M (ABOUT)

UNLESS OTHERWISE SPECIFIED TOLERANCE			
.X±0.20	.X±1°		
.XX±0.15	.XX±5°	<b>CHANT SINCERE CO.,LTD</b> TEL:886-02-86471251 FAX:886-02-86472362 RITA	
.XXX±0.10			
SCALE: AS SHOWN	UNIT: mm	DRAWN NAME: SFP ASSY.2X1	
DRAWN: RITA	01/29/2019	CHECKED: PRESS FIT, NON Grounding Pin 4/4	
CHECKED:		APPROVED:	
APPROVED:		PRODUCT NO. 902GHB2BCTAAX3A3	
REV. 1	DESCRIPTION	DATE	SIZE A4 REV. A FILE NAME: 902GHB2BCTAA03A3(X07)

REV.	1	DESCRIPTION	DATE
	2		
	3		
	4		
	5		
	6		
	7		
	8		
	9		
	10		