

WITH HEATSINK, WITH QUAD LIGHT PIPE

- MATERIALS:**
 BODY CAGE: STAINLESS STEEL, 0.25 THICKNESS
 EMI FINGER: STAINLESS STEEL
 HEATSINK: ALUMINUM
 HEATSINK CLIP: STAINLESS STEEL
 LIGHT PIPE MATERIAL: CLEAR POLYCARBONATE
- SURFACE FINISH:**
 BODY CAGE: CLEANING
 EMI SPRING: CLEANING AND HOLE SEALING
 HEATSINK: BLACK ANODIZED
 HEATSINK CLIP: CLEANING
- MATE WITH QSFP MSA COMPATIBLE TRANSCEIVER.**
- REFERENCE DOCUMENTS:**
 PRODUCT SPECIFICATION: QSFP MSA
- THIS PRODUCT COMPLY TO ROHS DIRECTIVE 2011/65/EU.**

PART NO.

902 G X A1 P 5 B C6 4 1 A 0
1 2 3 4 5 6 7 8 9 10 11 12

- | | |
|--|--|
| 1.SERIES NO. | 8.TYPE OPTION: C6=QSFP+ 28G Cage |
| 2.TYPE: G=PressFit | 9.SHELL PLATING/TYPE:
1=NO Plating/Through Bezel
4=NO Plating/Through Bezel(2 Legs)
7=NO Plating/Through Bezel(1 Legs) |
| 3.GREEN OPTION:
E=RoHS (For W/O Light Pipe)
G=RoHS+HF (For W/Light Pipe) | 10.PROCESS OPTION:
0=W/O Heatsink, Open Top
C=W/O Heatsink, Close Top
1=W/PCI(Heatsink 4.2mm)
2=W/SAN(Heatsink 6.5mm)
3=W/Networking(Heatsink 13.5mm) |
| 4.PORT NO: A1=1x1 | 11.PACKAGE OPTION:
A=Tray |
| 5.CONTACT TYPE(CAGE MATERIALS):
P=Non Distribution(STAINLESS STEEL)
S=Non Distribution(SILVER COPPER) | 12.INSULATOR COLOR:
0=Non Function |
| 6.LIGHT PIPE OPTION:
0=W/O Light Pipe
1=W/Single Light Pipe(Round)(Dim. A=9.7mm)
2=W/Double Light Pipe(Round)(Dim. A=9.7mm)
5=W/Quad Light Pipe(Round)(Dim. A=9.7mm)
6=W/Light Pipe(Round)(Dim. A=10.7mm) | |
| 7.LIGHT PIPE DIM. OPTION:
0=W/O Light Pipe
1=φ2.67mm For Single Light Pipe
2=φ2.67mm For Double Light Pipe
3=φ2.00mm For Double Light Pipe
A=φ2.67mm For Quad Light Pipe
B=φ2.00mm For Quad Light Pipe | |

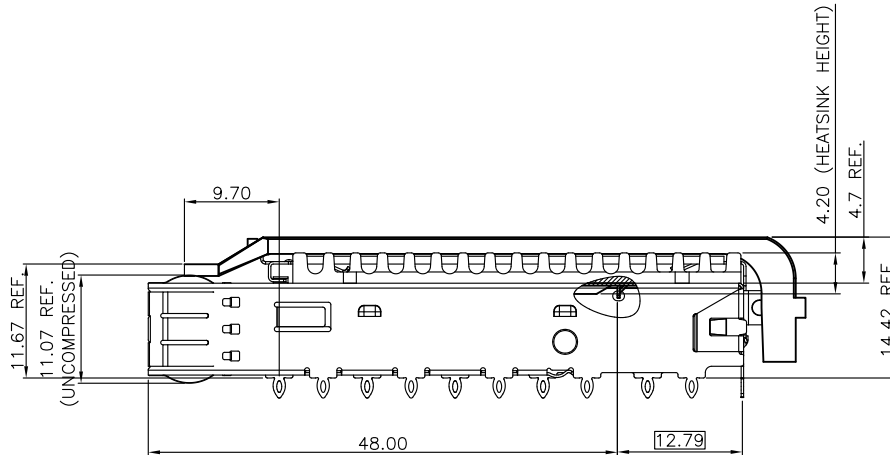
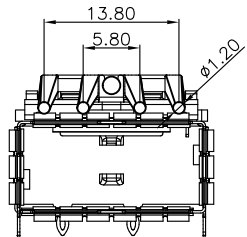
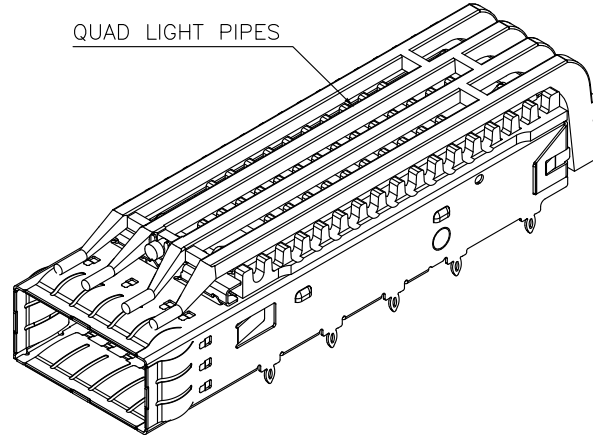
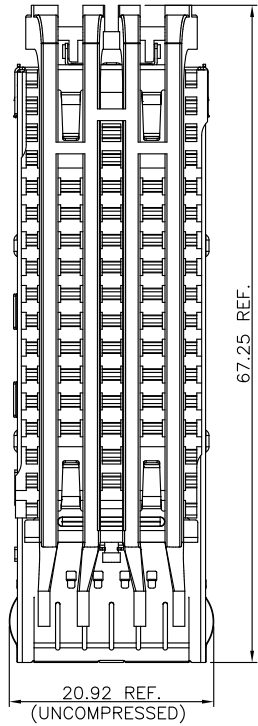

UNLESS OTHERWISE SPECIFIED TOLERANCE	
ANG.	2°
.0	0.30
.00	0.20
.000	0.10

SCALE: AS SHOWN	UNIT: mm
DRAWN kevin	01/09/2020
CHECKED	
APPROVED	





CHANT SINCERE CO.,LTD
 TEL:886-02-86471251 FAX:886-02-86472962

Title: QSFP+ 28G CAGE 1X1 Through Bezel WITH QUAD LIGHT PIPE	
Part NO. 902GGA1P5BC641A0	1/3
Code: (X8)(X07)	Customer:

Zone	Revision	Description	Date
1	2		
3			
4			
5			
6			
7			
8			
9			
10			

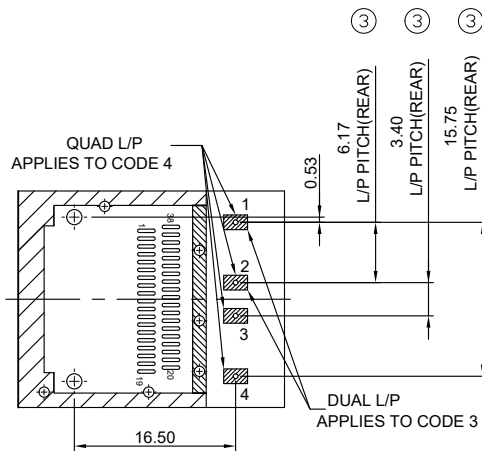
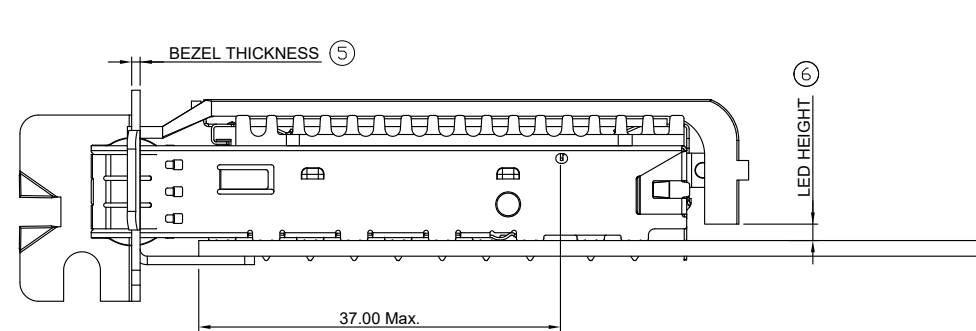
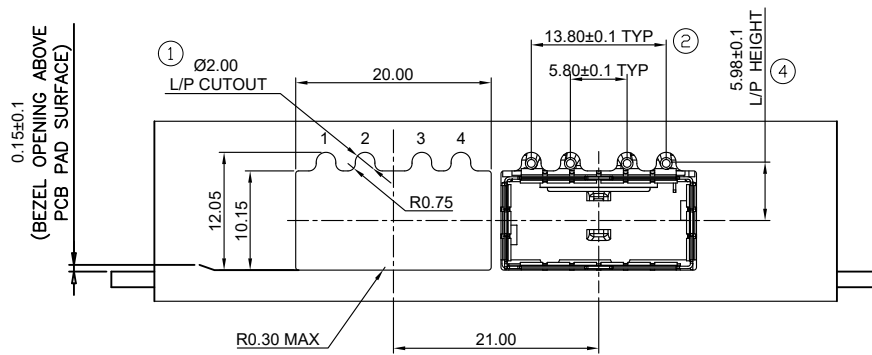
CODE	L/P APPEARANCE	L/P CUTOUT	L/P PITCH (FRONT)	L/P PITCH (REAR)	L/P HEIGHT	BEZEL THICKNESS	LED HEIGHT	REMARK
4	ROUND	Ø2.00	2,3=5.80 1,4=13.80	1,4=15.75 2,3=3.40	5.98	1.60	0.8~1.1	APPLIES TO QUAD L/P
		①	②	③	④	⑤	⑥	



UNLESS OTHERWISE SPECIFIED TOLERANCE		 CHANT SINCERE CO.,LTD TEL:886-02-86471251 FAX:886-02-86472962			
ANG.	2°				
.0	0.30	SCALE:	AS SHOWN	UNIT:	mm
.00	0.20	DRAWN	kevin	01/09/2020	Title:
.000	0.10	CHECKED			QSFP+ 28G CAGE 1X1 Through Bezel WITH QUAD LIGHT PIPE
		APPROVED			Part NO.
					902GGA1P5BC641A0
					Code: (X8)(X07) Customer:

Zone	Revision	Description	Date	SIZE	REV.	Code:	Customer:
1	2	3	4	5	6	7	8

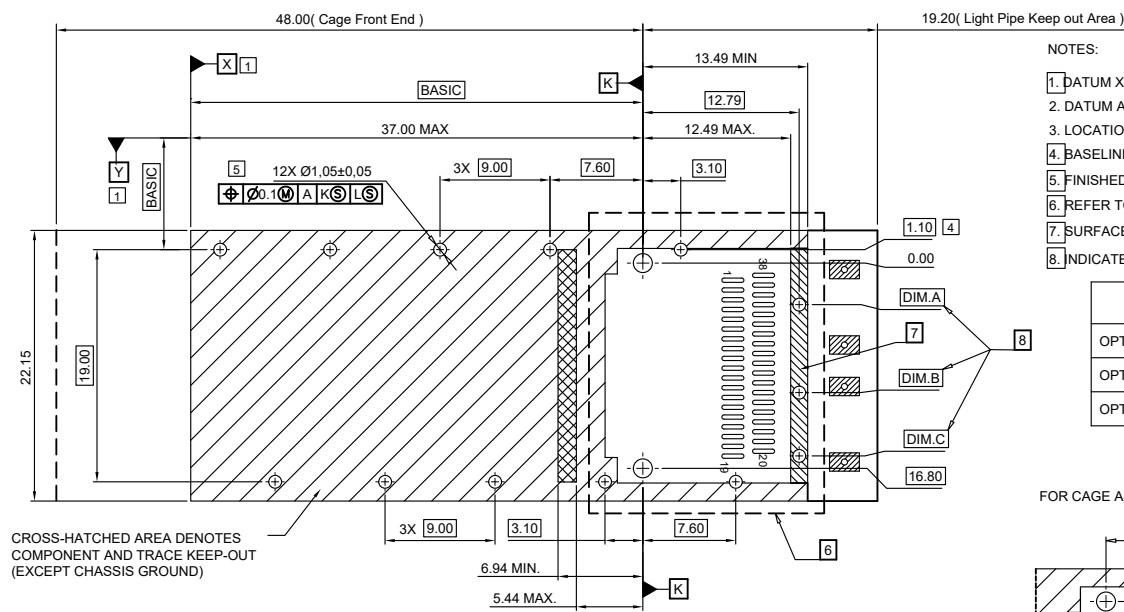

- NOTES:
- DATUM X & Y ARE ESTABLISHED BY THE CUSTOMER'S FIDUCIAL
 - DATUM A IS THE TOP SURFACE OF THE HOST BOARD
 - LOCATION OF THE EDGE OF PCB IS APPLICATION SPECIFIC
 - BASELINE FOR THESE DIMENSIONS IS THE CENTER OF COMPLIANT PIN HOLE.
 - FINISHED HOLE SIZE
 - REFER TO SFF8662 FOR CONNECTOR FOOTING DIMENSIONS
 - SURFACE TRACES PERMITTED WITHIN THIS SHADED AREA
 - INDICATED HOLES ARE OPTIONAL (SEE TABLE FOR REAR PIN CONFIGURATION)

	# OF REAR PIN PER PORT	DIM.A	DIM.B	DIM.C
OPTION 1	2 REAR LEGS	3.40	10.60	N/A
OPTION 2	1 REAR LEG	N/A	N/A	15.78
OPTION 3	0 REAR LEG	N/A	N/A	N/A

CROSS-HATCHED AREA DENOTES COMPONENT AND TRACE KEEP-OUT (EXCEPT CHASSIS GROUND)

RECOMMENDED SINGLE SIDE PC BOARD LAYOUT

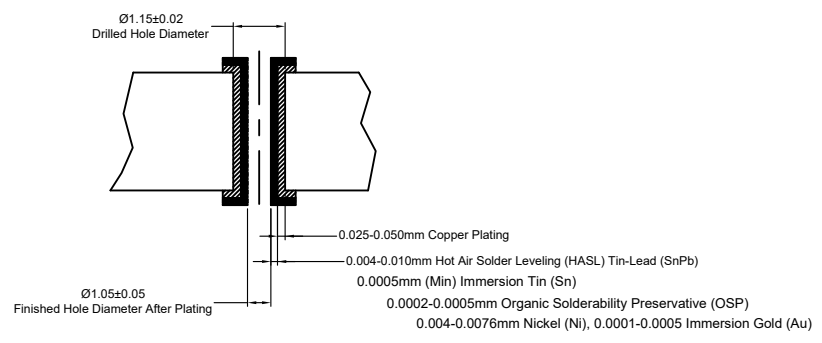

FINISHED HOLE SIZE SPECS

FOR CAGE ASSEMBLIES WITH LIGHT PIPES

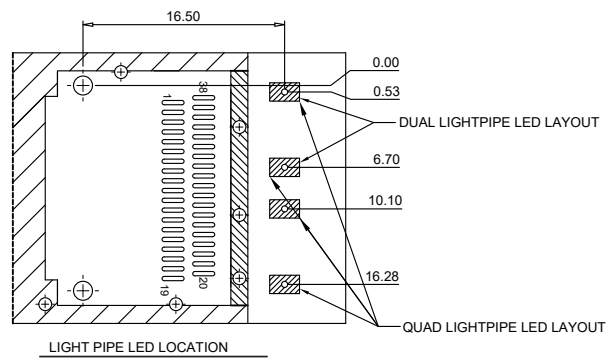

LIGHT PIPE LED LOCATION

UNLESS OTHERWISE SPECIFIED TOLERANCE	
ANG.	2°
.0	0.30
.00	0.20
.000	0.10



CHANT SINCERE CO.,LTD
TEL:886-02-86471251 FAX:886-02-86472962

SCALE:	AS SHOWN	UNIT:	mm
DRAWN	kevin	DATE	01/09/2020
CHECKED			
APPROVED			

Title: QSFP+ 28G CAGE 1X1 Through Bezel WITH QUAD LIGHT PIPE 3/3
Part NO. 902GGA1P5BC641A0
Code: (X8)(X07) Customer:

Zone	Revision	Description	Date	SIZE	REV.	Code:	Customer:
1	2	3	4	5	6	7	8