

1.MATERIAL:
 CAGE: SILVER ALLOY, THICKNESS 0.25mm
 LIGHT PIPE: CLEAR POLYCARBONATE
 2.PACKAGING: TRAY PACKAGING
 3.TEMPERATURE RANGE:
 OPERATING : -40°C TO +85°C
 NON OPERATING : -55°C TO +105°C

PART NUMBER:

902 G X B1 S V X C2 X 0 A 0
 1 2 3 4 5 6 7 8 9 10 11 12

- 1.SERIES NO.
- 2.TYPE: G=PressFit
- 3.GREEN OPTION:
 E=RoHS(For W/O Light Pipe)
 G=RoHS+HF(For W/Light Pipe)
- 4.PORT NO: B1=1x1(DIP=2.05mm)
- 5.CONTACT TYPE:
 S=SILVER COPPER
- 6.STRUCTURE TYPE:
 V=with Light Pipe Structure
- 7.LIGHT PIPES TYPE:
 0=W/O Light Pipe
 2=W/Light Pipe(Un-assembly)
- 8.TYPE OPTION:
 C2=SFP+ Cage
- 9.SHELL PLATING/TYPE:
 0=Non Plating/Spring
 N=Ni Plating/Spring
- 10.PROCESS OPTION:
 0=without Heatsink
- 11.PACKAGE OPTION:
 A=Tray
- 12.INSULATOR COLOR:
 0=Non Function

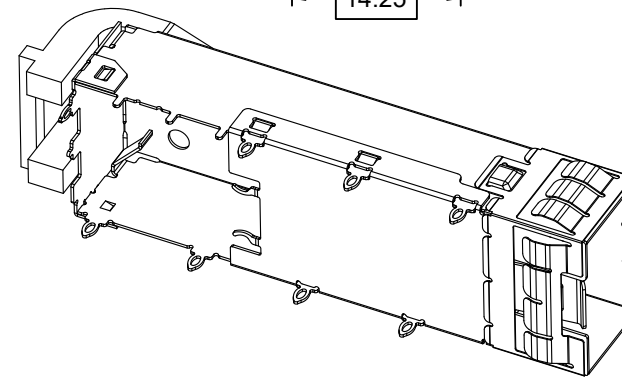
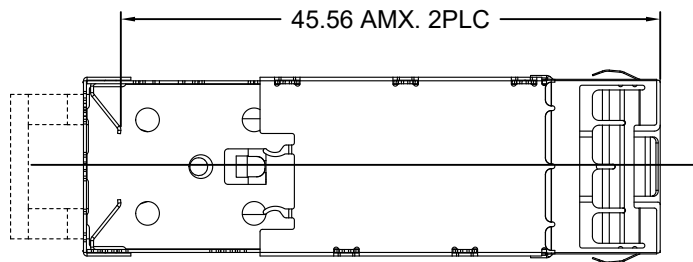
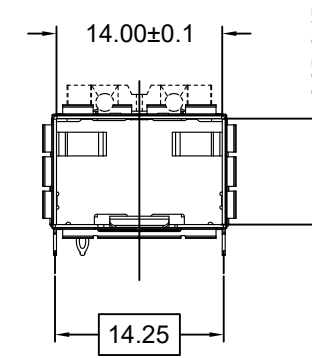
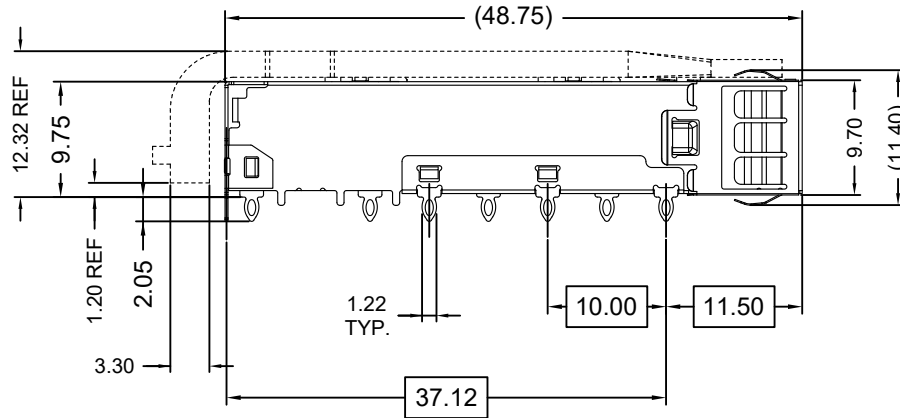
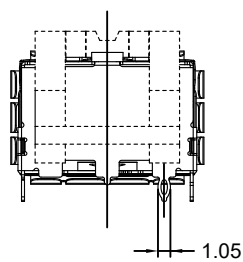
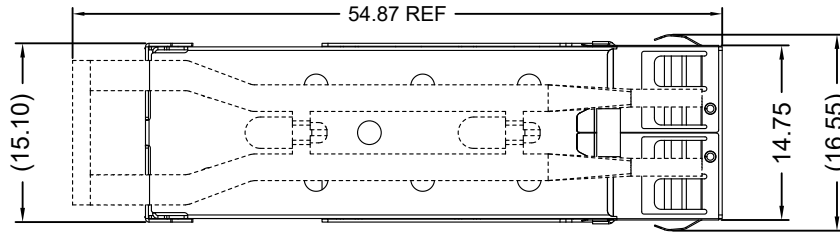

UNLESS OTHERWISE SPECIFIED TOLERANCE	
.X	1°
.0	0.20
.00	0.15
.000	0.10
SCALE:	AS SHOWN
UNIT:	mm
DRAWN:	PEARL
CHECKED:	
APPROVED:	



CHANT SINCERE CO.,LTD
 TEL:886-02-86471251 FAX:886-02-86472362

DRAWN NAME:
 SFP+ CAGE .1X1 PRESS FIT
 1/5

PRODUCT NO. 902GXB1SVXC2X0A0

FILE NAME: 902GEB1SVOC2N0A0(X07)

REV.	DESCRIPTION	DATE	SIZE	REV.	FILE NAME
1			A4	X2	

CROSS-HATCHED AREA DENOTES COMPONENT AND TRACE KEEP-OUT (EXCEPT CHASSIS GROUND)

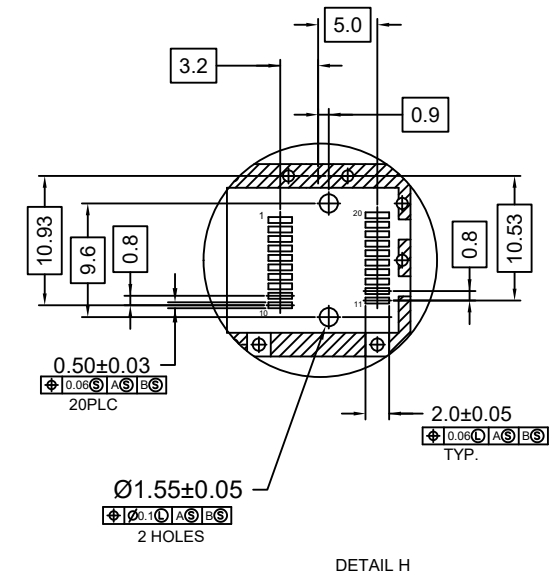
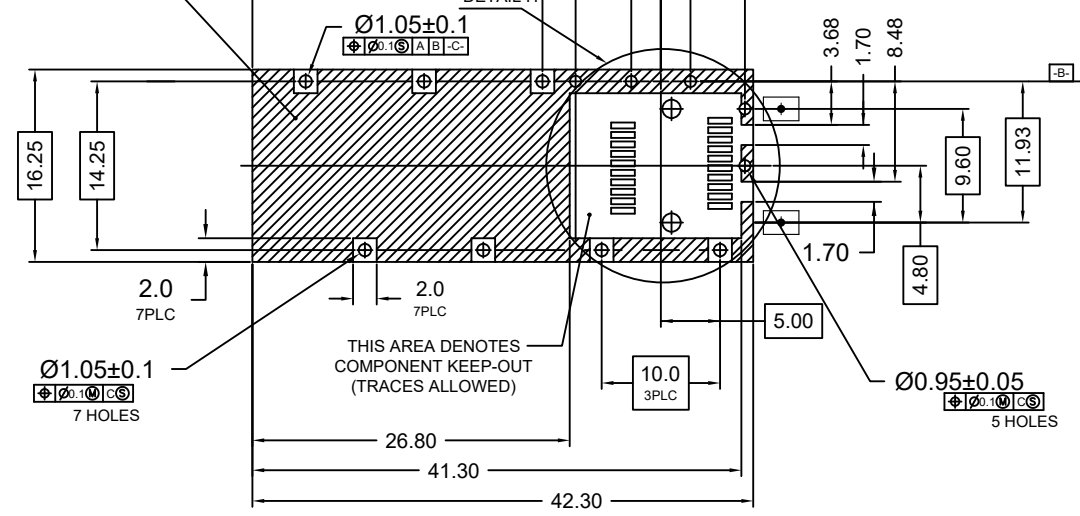

ECOMMENDED PCB CONFIGURATION

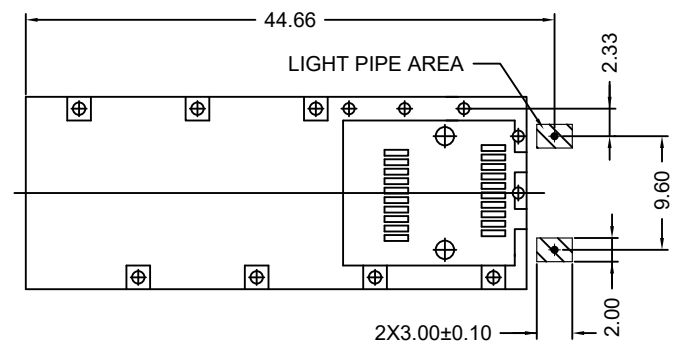

UNLESS OTHERWISE SPECIFIED TOLERANCE	
.X	1"
.0	0.20
.00	0.15
.000	0.10
SCALE:	AS SHOWN
UNIT:	mm
DRAWN:	PEARL
CHECKED:	
APPROVED:	

OXOC

CHANT SINCERE CO.,LTD
TEL:886-02-86471251 FAX:886-02-86472362

DRAWN NAME: SFP+ CAGE .1X1 PRESS FIT 2/5

PRODUCT NO. 902GXB1SVXC2X0A0

FILE NAME: 902GEB1SV0C2N0A0(X07)

REV.	DESCRIPTION	DATE	SIZE	REV.	FILE NAME
1			A4	X2	
2					
3					
4					
5					
6					
7					
8					
9					
10					

CROSS-HATCHED AREA DENOTES COMPONENT AND TRACE KEEP-OUT (EXCEPT CHASSIS GROUND)

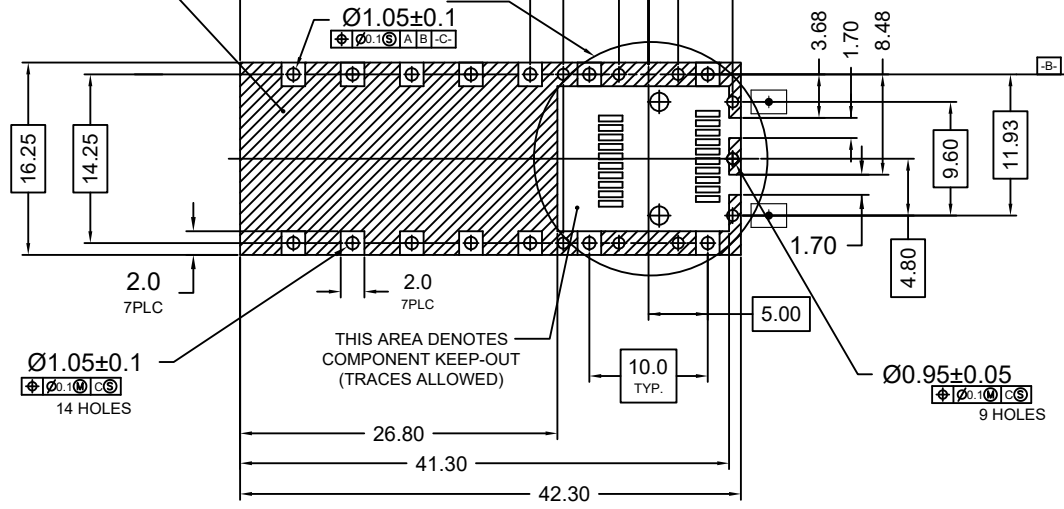

RECOMMENDED PCB CONFIGURATION WITH KEEP-OUT AREAS BELLY TO BELLY APPLICATIONS

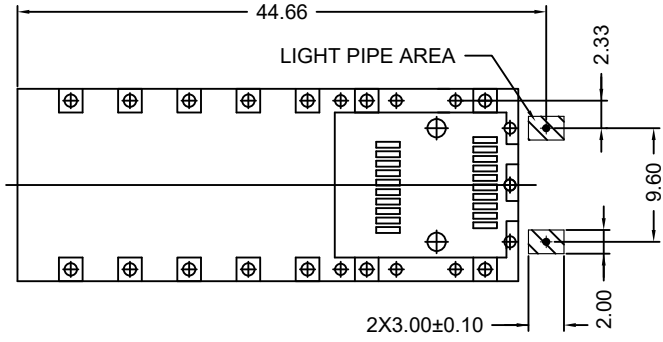
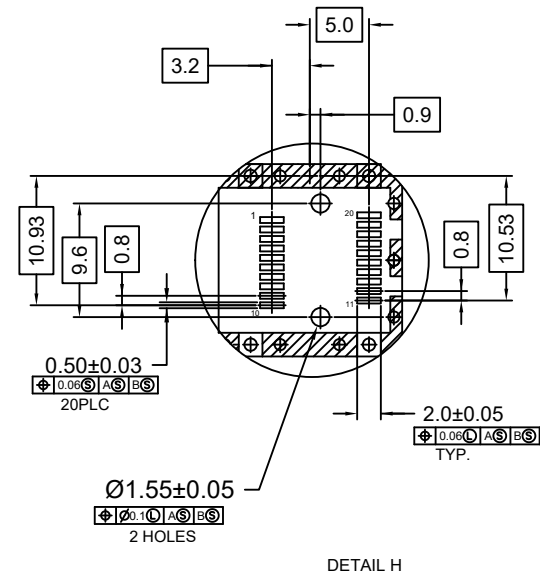

UNLESS OTHERWISE SPECIFIED TOLERANCE	
.X	1"
.0	0.20
.00	0.15
.000	0.10
SCALE:	AS SHOWN
UNIT:	mm
DRAWN:	PEARL
CHECKED:	
APPROVED:	



CHANT SINCERE CO.,LTD
TEL:886-02-86471251 FAX:886-02-86472362

DRAWN NAME: SFP+ CAGE .1X1 PRESS FIT
3/5

PRODUCT NO. 902GXB1SVXC2X0A0

FILE NAME: 902GEB1SV0C2N0A0(X07)

REV.	DESCRIPTION	DATE	SIZE	REV.
1			A4	X2

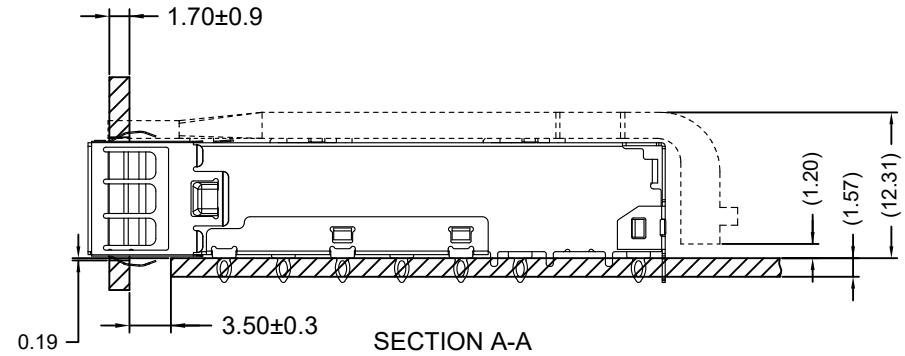
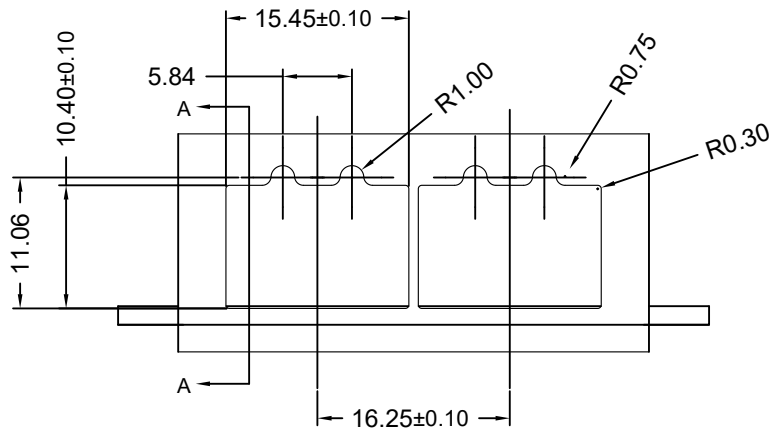

RECOMMENDED BEZEL DESIGN

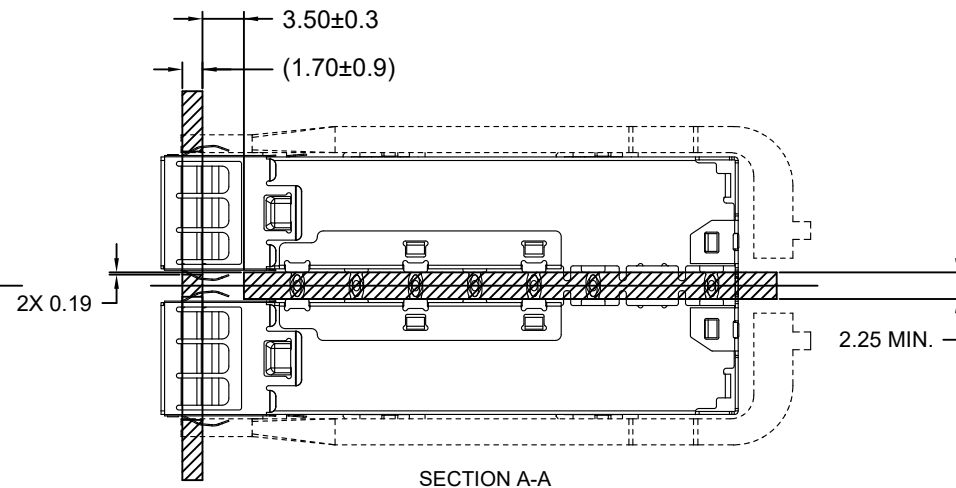
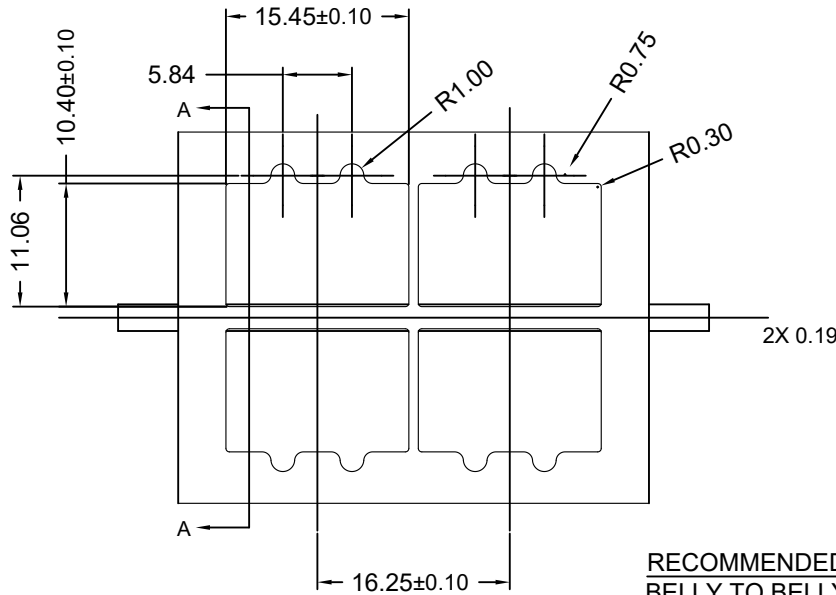

RECOMMENDED BEZEL DESIGN
BELLY TO BELLY APPLICATIONS

UNLESS OTHERWISE SPECIFIED TOLERANCE

.X	1°
.0	0.20
.00	0.15
.000	0.10



SCALE:	AS SHOWN	UNIT:	mm
DRAWN:	PEARL	03/14/2019	
CHECKED:			
APPROVED:			

CHANT SINCERE CO.,LTD
TEL:886-02-86471251 FAX:886-02-86472362

DRAWN NAME:
SFP+ CAGE .1X1 PRESS FIT
4/5

PRODUCT NO. 902GXB1SVXC2X0A0

FILE NAME: 902GEB1SV0C2N0A0(X07)

REV.	DESCRIPTION	DATE

SIZE	A4	REV.	X2
------	----	------	----

PACKAGE INFORMATION AND LABEL

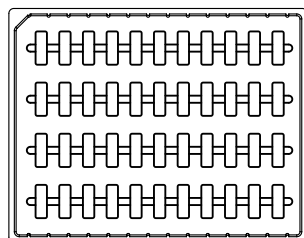

1. PRODUCTS IN TRAYS

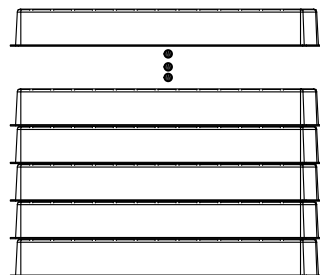

2. TRAYS OVERLAY:
(THE NEXT TRAY NEED ROTATE 180 DEGREE AND PUT IT ON PREVIOUS TRAY.)
(相邻两个吸塑间水平方向成180度摆放)

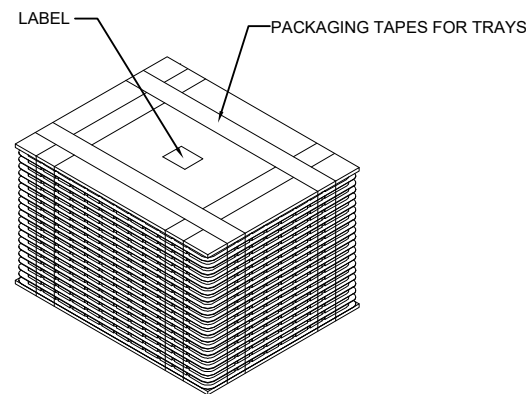

3. LABEL & PACKAGING TAPES FOR TRAYS:

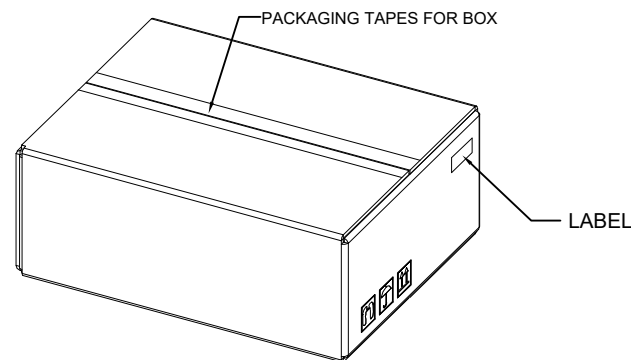

4. LABEL & PACKAGING TAPES FOR BOX

PACKAGING LISTS	
ITEM	QTY
PRODUCT	220 PCS
TRAY	5 PCS
BOX(L340*W265*H200MM)	1 PCS
LABLE	2 PCS
PACKAGING TAPES	8 M (ABOUT)

UNLESS OTHERWISE SPECIFIED TOLERANCE		
.X	1°	
.0	0.20	CHANT SINCERE CO.,LTD TEL:886-02-86471251 FAX:886-02-86472362
.00	0.15	
.000	0.10	
SCALE:	AS SHOWN	UNIT: mm
DRAWN:	PEARL	03/14/2019
CHECKED:		
APPROVED:		
REV.		
DRAWN NAME:		DRAWN NAME:
SFP+ CAGE .1X1 PRESS FIT		SFP+ CAGE .1X1 PRESS FIT
5/5		5/5
PRODUCT NO.		PRODUCT NO.
902GXB1SVXC2X0A0		902GXB1SVXC2X0A0
FILE NAME:		FILE NAME:
902GEB1SV0C2N0A0(X07)		902GEB1SV0C2N0A0(X07)

REV.	DESCRIPTION	DATE