

SPECIFICATION

MATERIAL

CAGE: STAINLESS STEEL, 0.25 THICKNESS

EMI SPRING: STAINLESS STEEL

HEAT SINK CLIP: STAINLESS STEEL, 0.30 THICKNESS

HEAT SINK: AL1050 + AL5052

FINISH

HEAT SINK: NICKEL PLATING

MIN. PC BOARD THICKNESS: SINGLES SIDED: 1.60mm min.

DOUBLE SIDED: 3.00mm min.

MATE WITH QSFP MSA COMPATIBLE TRANSCEIVER.

Part no.

902 G E A1 P 0 0 C8 4 2 A 0
1 2 3 4 5 6 7 8 9 10 11 12

1.SERIES NO.

902=QSFP Series

2.G=Press Fit

3.GREEN OPTION:

E=RoHS

4.CONTACT NUMBER:

A1=1X1

5.CONTACT TYPE:

P=Non Distribution

6.LIGHT PIPE OPTION:

0=W/O Light Pipe

7.LIGHT PIPE DIM. OPTION:

0=W/O Light Pipe

8.APPLY TYPE:

C8=QSFP DD CAGE

9.SHELL PLATING/TYPE:

4=NO Plating/Through Bezel
(2 Legs)

10.PROCESS OPTION:

2=W/PCI(Heatsink 4.2mm)
+Light pipe

11.PACKAGE OPTION:

A=Tray

12.INSULATOR COLOR:

0=Standard

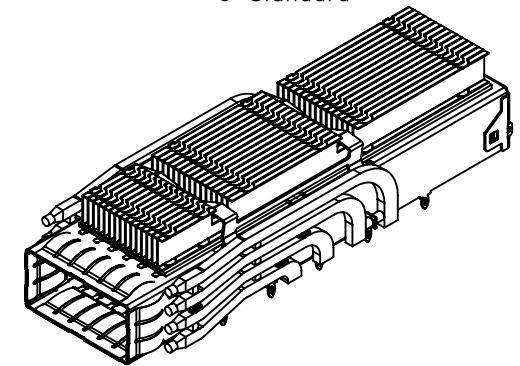

UNLESS OTHERWISE SPECIFIED TOLERANCE	
ANG.	±5°
0.	±0.50
.0	±0.30
.00	±0.20

SCALE: AS SHOWN	UNIT: mm
-----------------	----------

DRAWN Brian	2021/10/07
-------------	------------

CHECKED	
---------	--

APPROVED	
----------	--

SIZE A4	REV. X1
---------	---------

OXOC

CHANT SINCERE CO.,LTD
TEL:886-02-86471251 FAX:886-02-86472962

Title: QSFP-DD CAGE WITH LIGHT PIPE	1/2
-------------------------------------	-----

Part NO. C-902GEA1P00C842A0

Factory:	Customer:
----------	-----------

Zone	Revision	Description	Date
1	2	3	4

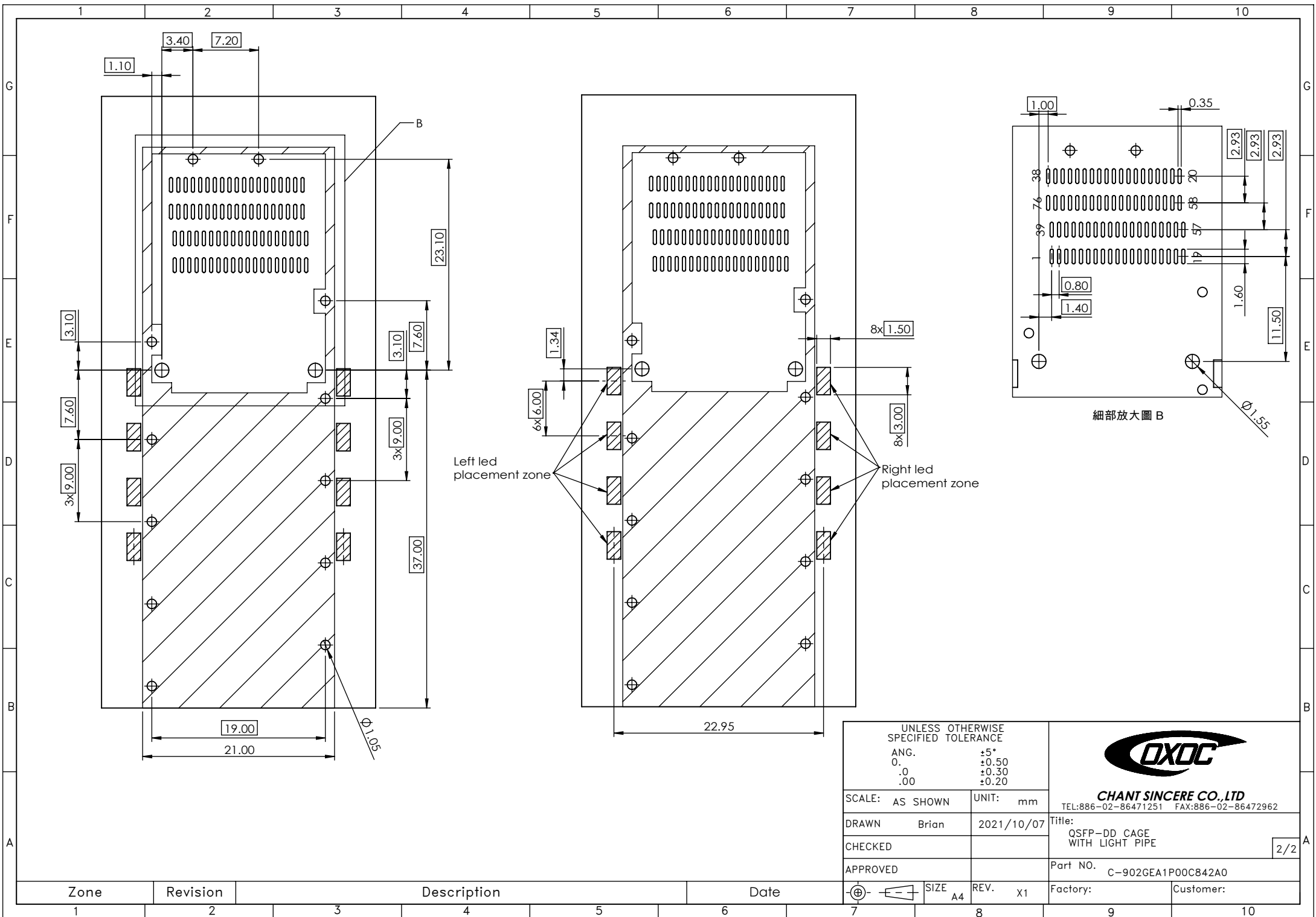

Left led placement zone

Right led placement zone

細部放大圖 B

UNLESS OTHERWISE SPECIFIED TOLERANCE	
ANG.	±5°
0.	±0.50
.0	±0.30
.00	±0.20

SCALE: AS SHOWN UNIT: mm

DRAWN Brian 2021/10/07

CHECKED

APPROVED

SIZE A4 REV. X1



CHANT SINCERE CO., LTD

TEL:886-02-86471251 FAX:886-02-86472962

Title: QSFP-DD CAGE WITH LIGHT PIPE

Part NO. C-902GEA1P00C842A0

Factory: Customer:

Zone	Revision	Description	Date
1	2		
2			
3			
4			
5			
6			
7			
8			
9			
10			