

剖面圖 A-A

SPECIFICATION

MATERIAL

Insulator: Thermoplastic, rated UL94V-0

Contact: Copper Alloy

Cover: Thermoplastic, rated UL94V-0

CONTACT PLATING

Underplate: 50u"~100u" Nickel

Contact area: Selective gold

Solder tails area: 100u"~200u" Tin (Lead Free)

ELECTRICAL

Current rating: 0.5 A per contact

Rated voltage: 30 VDC per contact

Insulation resistance: 1000 Megaohms minimum

Dielectric withstanding voltage: 300 VDC for 1 minute

Storage Temperature: -20°C TO +85°C

Part no.

902 D D 38 B X T 06 0 1 C X

1 2 3 4 5 6 7 8 9 10 11 12

1.Series No.

902=SFP Series

2.D=SMT Type

3.Green option:

D=RoHS2 (Matte)(Halogen Free)

4.Contact number:

38=38 pin

5.Contact type:

B=Female

6.Contact area plating:

C=15u" Gold

D=30u" Gold

7.Solder tails plating:

T=100u"~200u" Tin

8.Apply type:

06=QSFP+ 28G

9.Shell plating:

0=none

10.Type:

1=Style A

11.Packing Style:

C=Tape reel

12.Insulator color:

3=Black

C=Black+Date Code

UNLESS OTHERWISE SPECIFIED TOLERANCE	
ANG.	± 5°
0.	± 0.50
.0	± 0.30
.00	± 0.20

SCALE: AS SHOWN UNIT: mm

DRAWN Jason_Huang 07/29/15'

CHECKED / /

APPROVED / /

SIZE A4 REV. X1



CHANT SINCERE CO.,LTD
TEL.886-02-86471251 FAX886-02-86472962

DRAWN NAME: QSFP+ 28G 38P Connector (1/2)
PRODUCT NO. 902DD38BXT0601CX
FILE NAME: C-902DD38BXT0601CX

REV.	DESCRIPTION	DATE	SIZE	REV.	FILE NAME
1			A4	X1	C-902DD38BXT0601CX

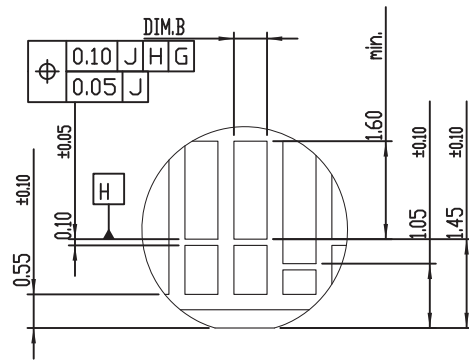
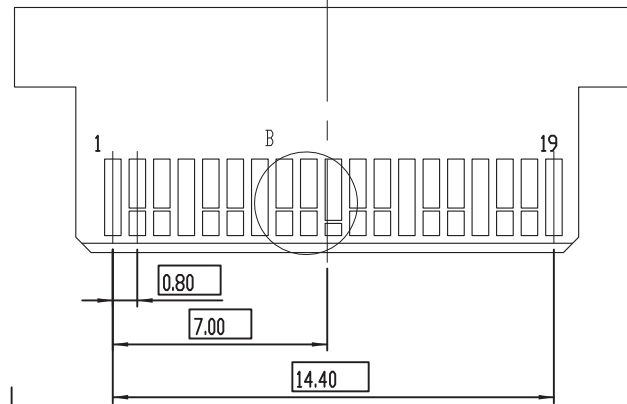
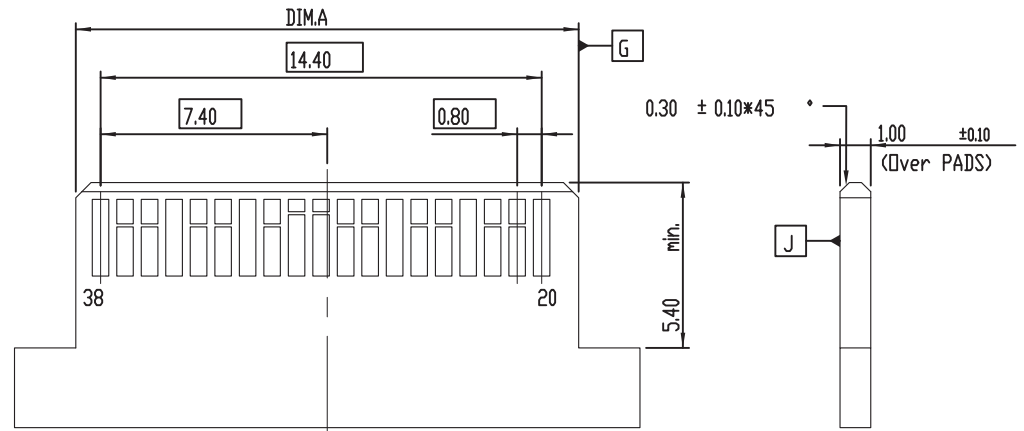
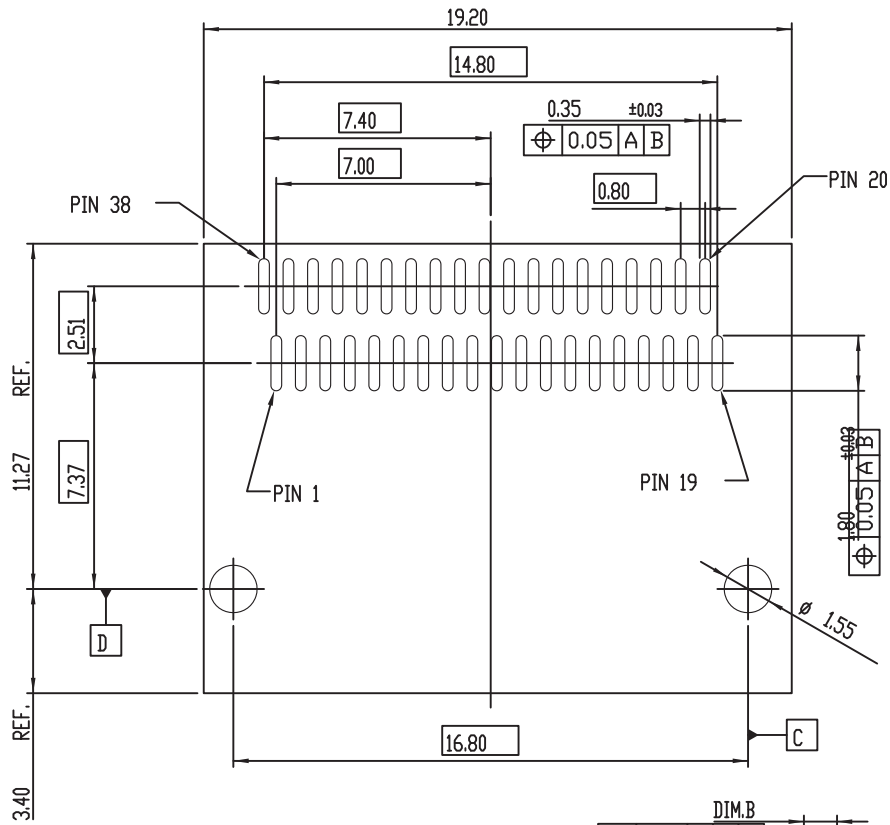

細部放大圖 B

For SIP
For CmK/Cpk

Designator	DIM.A	DIM.B
Paddle Card Width	16.42 ± 0.08	0.54 ± 0.04
	16.40 ± 0.10	0.60 ± 0.03

UNLESS OTHERWISE SPECIFIED TOLERANCE	
ANG.	± 5°
0.	± 0.50
.0	± 0.30
.00	± 0.20



CHANT SINCERE CO.,LTD
TEL.886-02-86471251 FAX886-02-86472962

SCALE:	AS SHOWN	UNIT:	mm
DRAWN	Jason_Huang	DATE:	07/29/15'
CHECKED			/ /
APPROVED			/ /

DRAWN NAME:	QSFP+ 28G 38P Connector (2/2)
PRODUCT NO.	902DD38BXT0601CX
FILE NAME:	C-902DD38BXT0601CX

REV.	DESCRIPTION	DATE	SIZE	A4	REV.	X1
1						
2						
3						
4						
5						
6						
7						
8						
9						
10						