

NOTES:

- 1.MATERIAL: COPPER ALLOY, THICKNESS 0.25mm
- 2.PACKAGING: TRAY PACKAGING
- 3.TEMPERATURE RANGE: -55°C TO +85°C

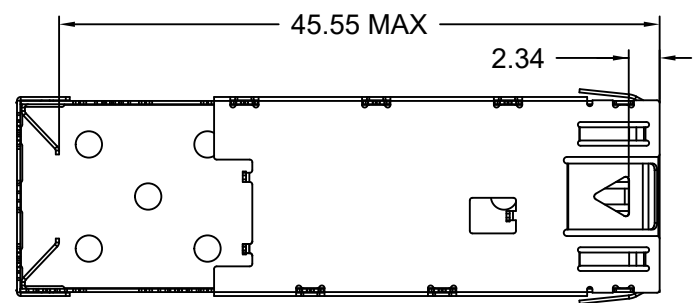
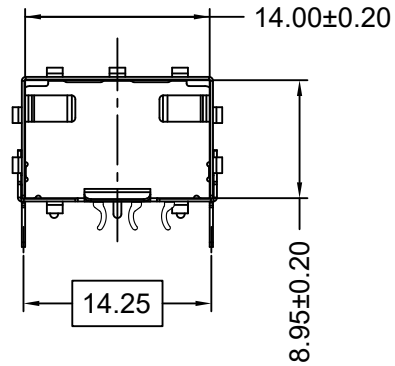
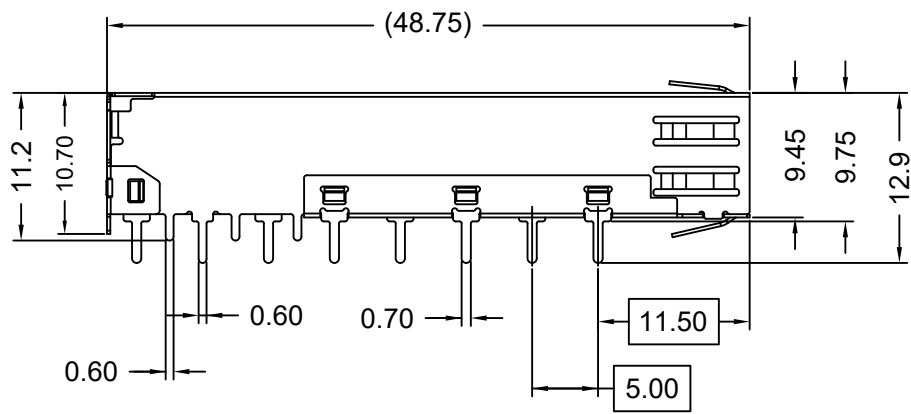
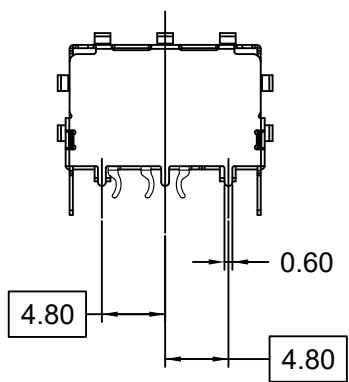

PART NUMBER:

902 A E A1 S 0 0 C1 0 0 A 0
 1 2 3 4 5 6 7 8 9 10 11 12

- 1.SERIES NO.
- 2.TYPE: A=Solder
- 3.GREEN OPTION: E=RoHS
- 4.PORT NO: A1=1x1
- 5.CONTACT TYPE: S=Non Distribution
- 6.LIGHT PIPE OPTION: 0=W/O Light Pipe
- 7.LIGHT PIPE DIM. OPTION: 0=W/O Light Pipe
- 8.TYPE OPTION: C1=SFP Cage
- 9.SHELL PLATING: 0=Nickel
- 10.PROCESS OPTION: 0=Standard
- 11.PACKAGE OPTION: A=Tray
- 12.INSULATOR COLOR: 0=Non Function

UNLESS OTHERWISE SPECIFIED TOLERANCE		 CHANT SINCERE CO.,LTD TEL:886-02-86471251 FAX:886-02-86472962	
X ±0.20	X ±1°		
XX ±0.15	XX ±5°	SCALE: AS SHOWN	UNIT: mm
.XXX ±0.10		DRAWN: PEARL	07/09/2019
		CHECKED:	DRAWN NAME: SFP 1X1 CAGE 1/4
		APPROVED:	PRODUCT NO. 902AEA1S00C100A0
		SIZE A4	REV. X1
			FILE NAME: 902AEA1S00C100A0(X07)

REV.	DESCRIPTION	DATE
1		
2		
3		
4		
5		
6		

CROSS-HATCHED AREA DENOTES COMPONENT AND TRACE KEEP-OUT (EXCEPT CHASSIS GROUND)

THIS AREA DENOTES COMPONENT KEEP-OUT (TRACES ALLOWED)

ECOMMENDED PCB CONFIGURATION

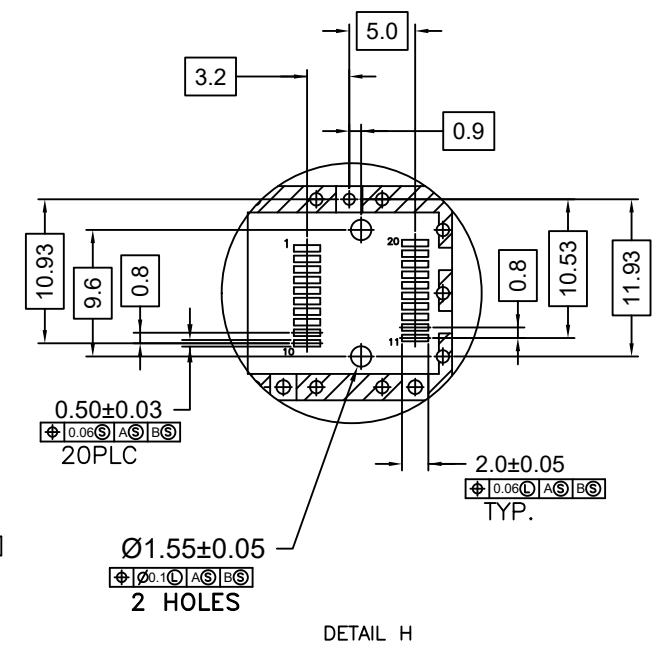
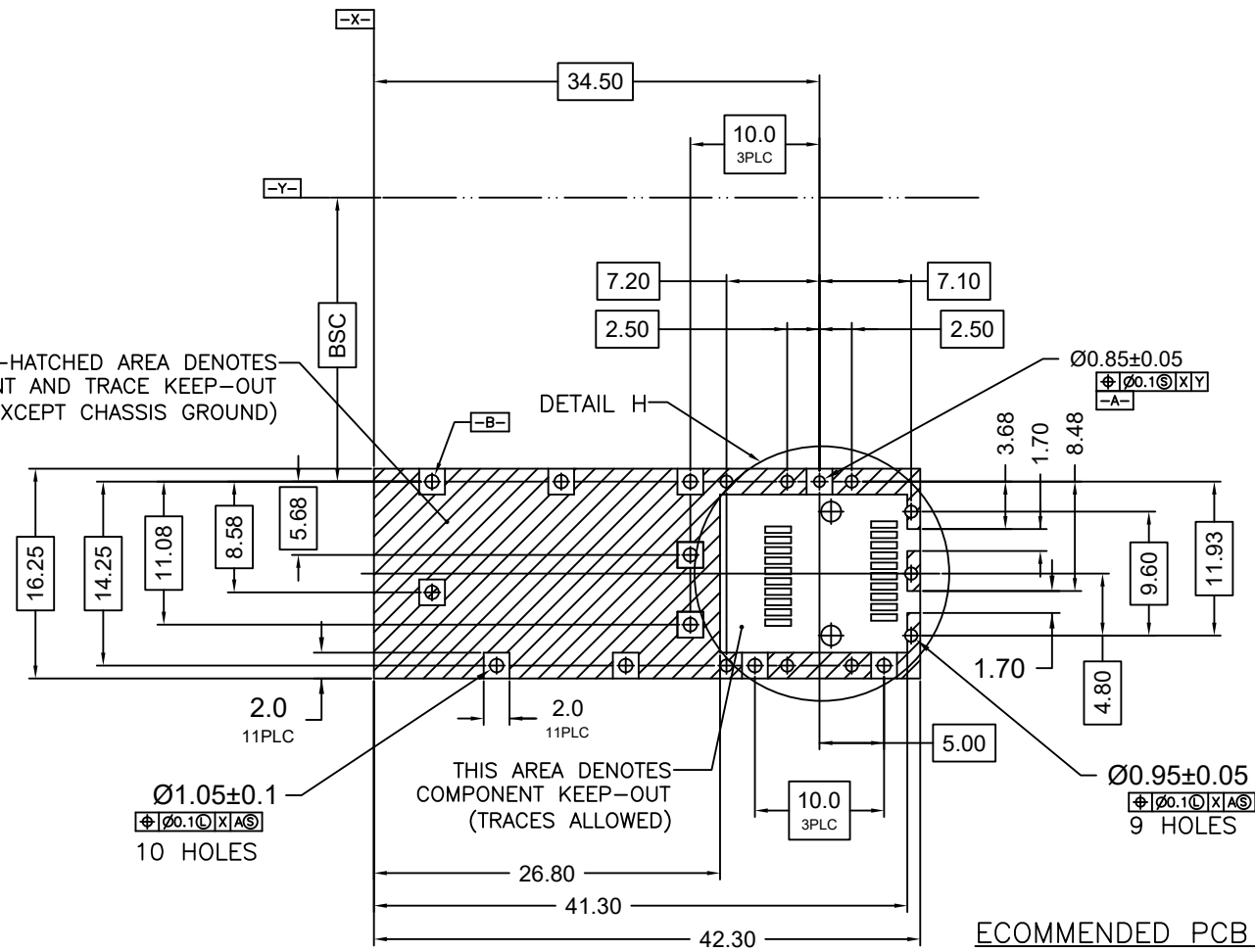

UNLESS OTHERWISE SPECIFIED TOLERANCE	
X ±0.20	X ±1°
XX ±0.15	XX ±5°
XXX ±0.10	
SCALE: AS SHOWN	UNIT: mm
DRAWN: PEARL	07/09/2019
CHECKED:	
APPROVED:	



CHANT SINCERE CO.,LTD
TEL:886-02-86471251 FAX:886-02-86472962

DRAWN NAME: SFP 1X1 CAGE 2/4
PRODUCT NO. 902AEA1S00C100AO
FILE NAME: 902AEA1S00C100AO(X07)

REV.	DESCRIPTION	DATE	SIZE	REV.
			A4	X1

1 2 3 4 5 6 7 8 9 10

G

F

E

D

C

B

A

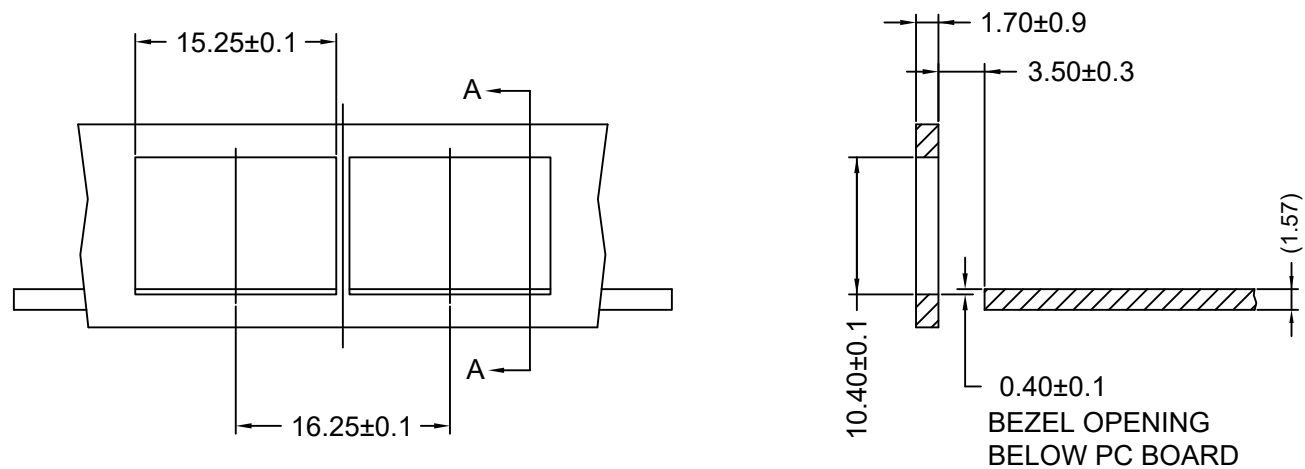

SECTION A-A

RECOMMENDED BEZEL DESIGN

UNLESS OTHERWISE SPECIFIED TOLERANCE		 CHANT SINCERE CO.,LTD TEL:886-02-86471251 FAX:886-02-86472962	
X ±0.20	X ±1°		
.XX ±0.15	.XX ±5°	SCALE: AS SHOWN	UNIT: mm
.XXX ±0.10		DRAWN: PEARL	07/09/2019
		CHECKED:	
		APPROVED:	
		PRODUCT NO.	902AEA1S00C100AO
		FILE NAME:	902AEA1S00C100AO(X07)

REV.	DESCRIPTION	DATE
1		
2		
3		
4		
5		
6		
7		
8		
9		
10		

G

F

E

D

C

B

A

PACKAGE INFORMATION AND LABEL

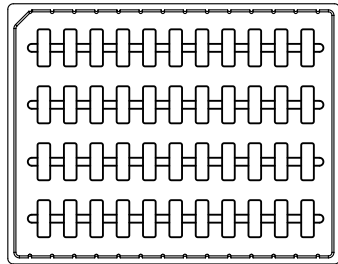

1. PRODUCTS IN TRAYS

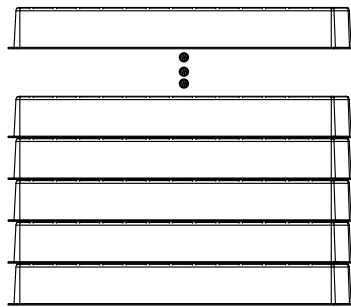

2. TRAYS OVERLAY:
(THE NEXT TRAY NEED ROTATE 180 DEGREE AND PUT IT ON PREVIOUS TRAY.)
(相邻两个吸塑间水平方向成180度摆放)

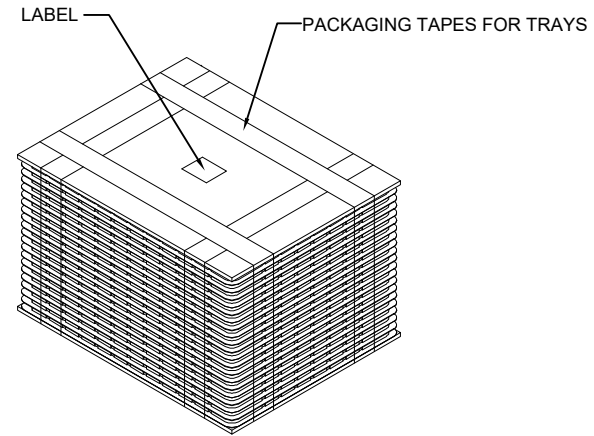

3. LABEL & PACKAGING TAPES FOR TRAYS:

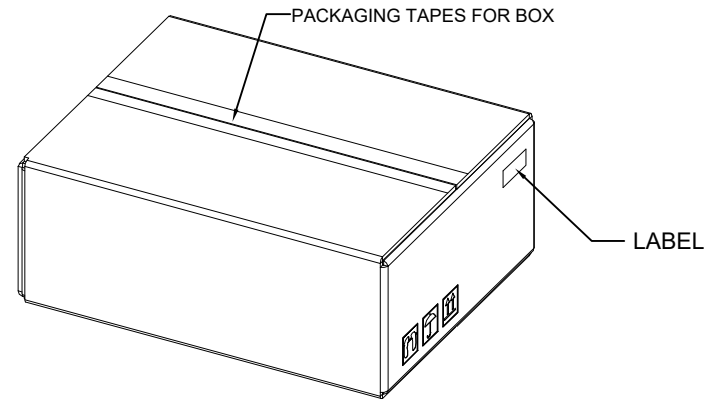

4. LABEL & PACKAGING TAPES FOR BOX

PACKAGING LISTS	
ITEM	Q'TY
PRODUCT	396 PCS
TRAY	9 PCS
BOX(L340*W265*H200MM)	1 PCS
LABLE	2 PCS
PACKAGING TAPES	8 M (ABOUT)

UNLESS OTHERWISE SPECIFIED TOLERANCE		 CHANT SINCERE CO.,LTD TEL:886-02-86471251 FAX:886-02-86472962
.X ±0.20	.X ±1°	
.XX ±0.15	.XX ±5°	SCALE: AS SHOWN UNIT: mm
.XXX ±0.10		DRAWN: PEARL 07/09/2019 DRAWN NAME: SFP 1X1 CAGE 4/4
		CHECKED:
		APPROVED:
		PRODUCT NO. 902AEA1S00C100A0
		FILE NAME: 902AEA1S00C100A0(X07)

REV.	DESCRIPTION	DATE
1		
2		
3		
4		
5		
6		
7		
8		
9		
10		