

NOTES:
 1.MATERIAL:
 01 SFP TOP CAGE : COPPER ALLOY
 02 SFP BOTTOM CAGE : COPPER ALLOY
 2. FINISH
 SFP TOP CAGE : NI-PLATED OVER ALL
 SFP BOTTOM CAGE : NI-PLATED OVER ALL
 3. TEMPERATURE:
 OPERATION : -40°C TO +85°C
 STORAGE : -55°C TO +105°C
 4.PACKAGING: TAPE & REEL

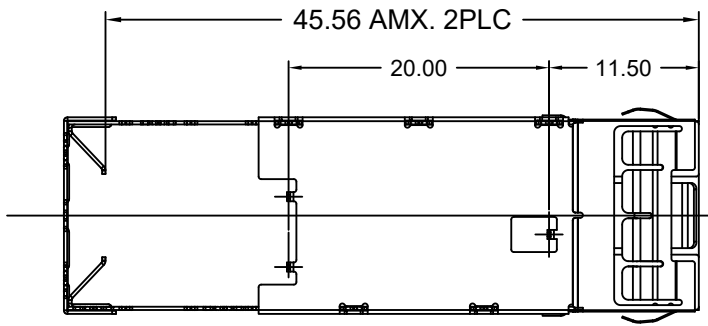
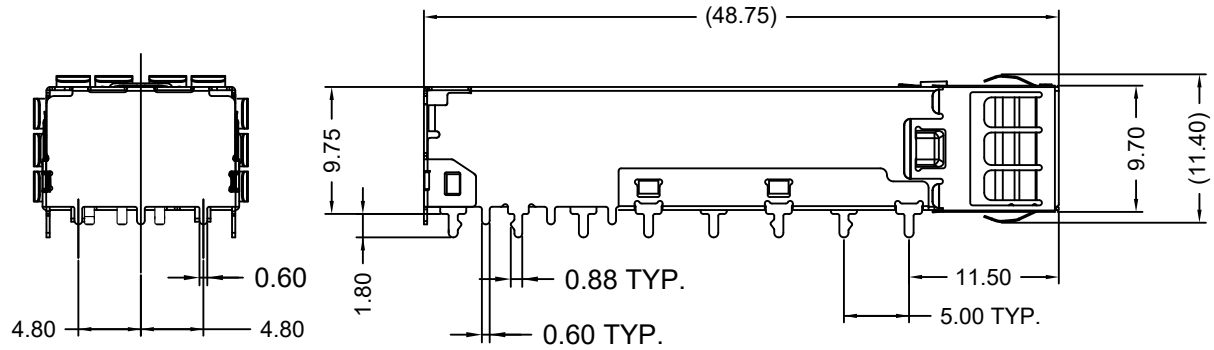
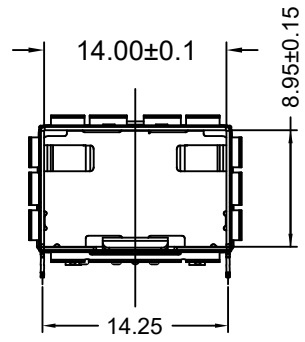
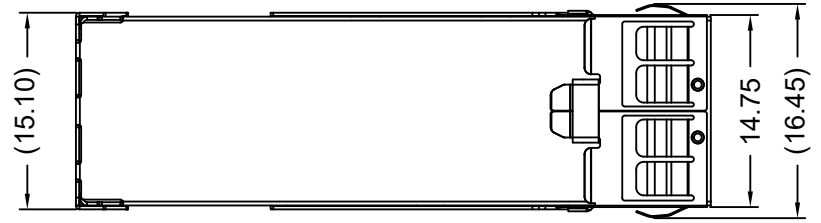

PART NUMBER:

902 A E 11 S W 0 C 2 X 0 A 0
 1 2 3 4 5 6 7 8 9 10 11 12

- | | | | |
|---------------------|-----|-----------------------|----|
| 1.SERIES NO. | 902 | 9.SHELL PLATING/TYPE: | A |
| 2.TYPE: A=DIP | E | 0=Non Plating/Spring | |
| 3.GREEN OPTION: | 11 | N=Ni Plating/Spring | |
| E=RoHS | | 10.PROCESS OPTION: | 11 |
| 4.PORT NO: | S | 0=W/O Light Pipe | |
| 11=1x1(DIP L=1.8mm) | | 11.PACKAGE OPTION: | W |
| 5.CONTACT TYPE: | 0 | C=Tape & Reel | |
| S=SILVER COPPER | | 12.INSULATOR COLOR: | 0 |
| 6.TYPE: | 2 | 0=Non Function | |
| W=WITHOUT TOP HOLES | | | |
| 7.LIGHT PIPES TYPE: | 11 | | |
| 0=W/O Light Pipe | | | |
| 8.TYPE OPTION: | 0 | | |
| C2=SFP+ Cage | | | |

UNLESS OTHERWISE SPECIFIED TOLERANCE	
.X	1°
.0	0.20
.00	0.15
.000	0.10



CHANT SINCERE CO.,LTD
 TEL:886-02-86471251 FAX:886-02-86472362

SCALE:	AS SHOWN	UNIT:	mm
DRAWN:	PEARL	DATE:	11/01/2018
CHECKED:			
APPROVED:			

DRAWN NAME:	SFP+ CAGE .1X1 DIP WITH EMI SPRINGS 1/4
PRODUCT NO.	902AE11SW0C2X0C0
FILE NAME:	902AE11SW0C200C0(X07)

REV.	DESCRIPTION	DATE	SIZE	REV.	FILE NAME
1			A4	X1	
2					
3					
4					
5					
6					
7					
8					
9					
10					

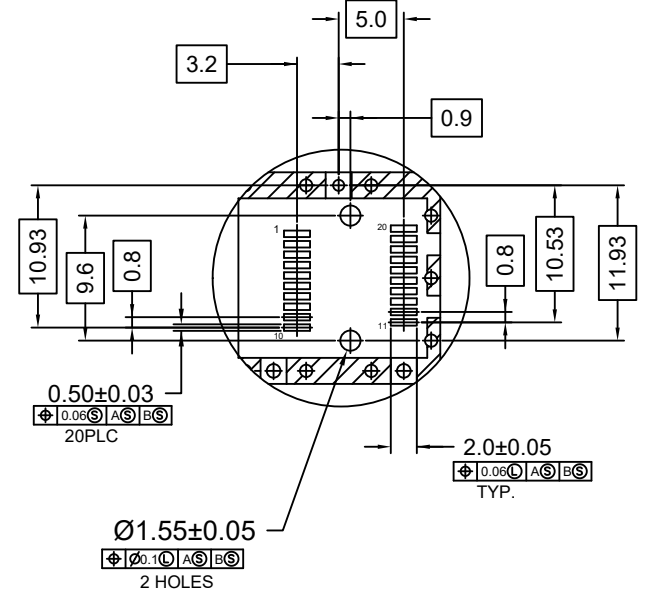
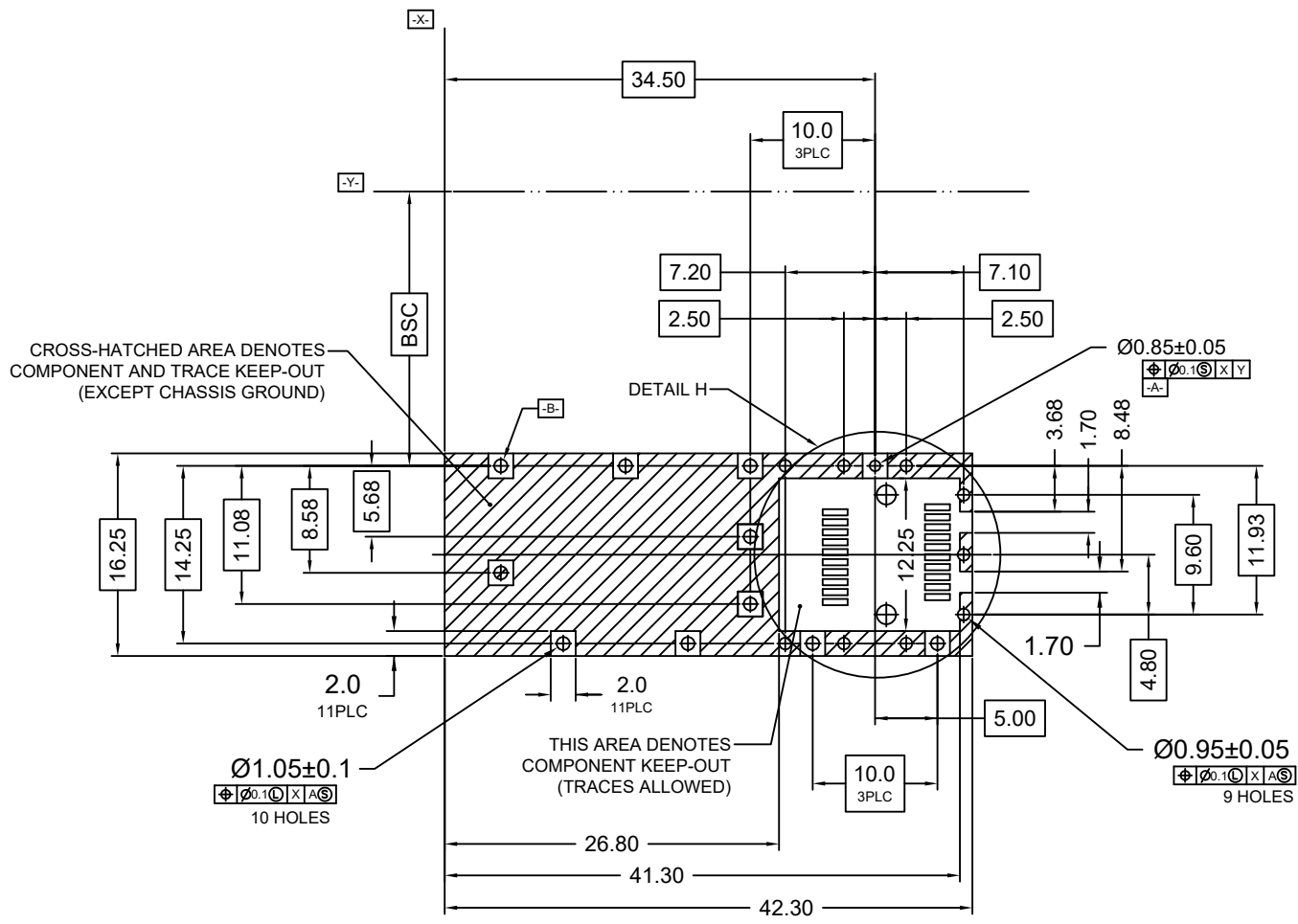

ECOMMENDED PCB CONFIGURATION

UNLESS OTHERWISE SPECIFIED TOLERANCE	
.X	1°
.0	0.20
.00	0.15
.000	0.10
SCALE:	AS SHOWN
UNIT:	mm
DRAWN:	PEARL
CHECKED:	
APPROVED:	

OXOC

CHANT SINCERE CO.,LTD
 TEL:886-02-86471251 FAX:886-02-86472362

DRAWN NAME: SFP+ CAGE .1X1 DIP WITH EMI SPRINGS 2/4

PRODUCT NO. 902AE11SW0C2X0C0

FILE NAME: 902AE11SW0C200C0(X07)

REV.	DESCRIPTION	DATE	SIZE	REV.	FILE NAME
1			A4	X1	902AE11SW0C200C0(X07)

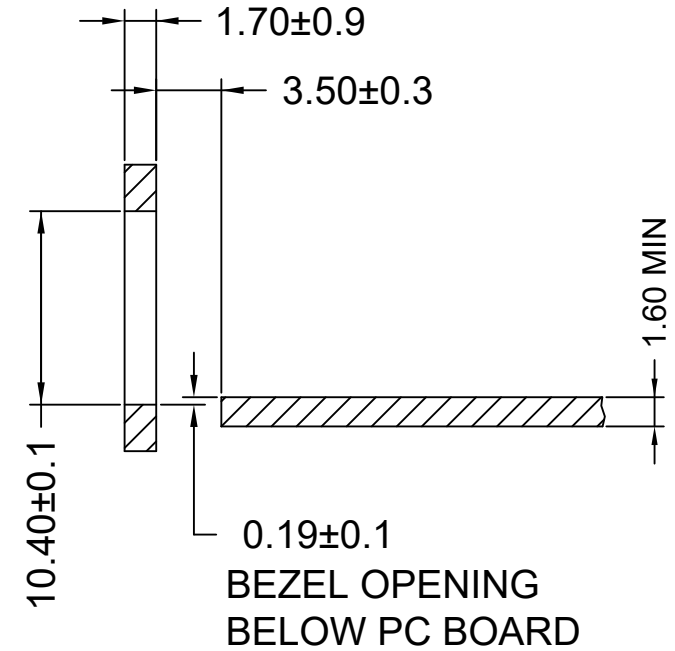
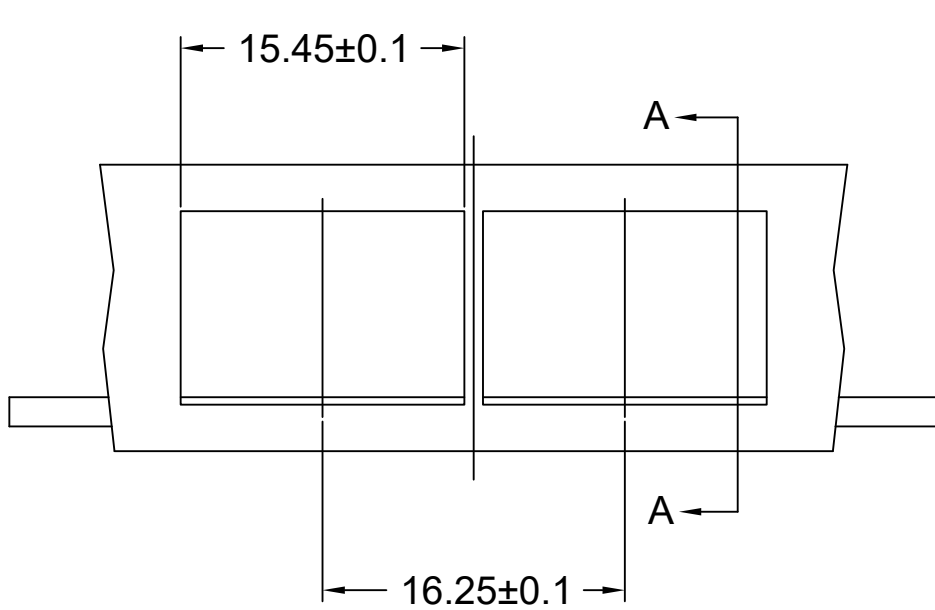



SECTION A-A

RECOMMENDED BEZEL DESIGN

UNLESS OTHERWISE SPECIFIED TOLERANCE		 CHANT SINCERE CO.,LTD TEL 886-02-86471251 FAX 886-02-86472362	
.X	1°		
.0	0.20	SCALE: AS SHOWN	UNIT: mm
.00	0.15	DRAWN: PEARL	11/01/2018
.000	0.10	CHECKED:	
		APPROVED:	
			DRAWN NAME: SFP+ CAGE .1X1 DIP WITH EMI SPRINGS 3/4
			PRODUCT NO. 902AE11SW0C2X0C0
			FILE NAME: 902AE11SW0C200C0(X07)

REV.	DESCRIPTION	DATE
1		
2		
3		
4		
5		
6		

		SIZE A4	REV. X1
---	---	---------	---------

PACKAGE INFORMATION AND LABEL

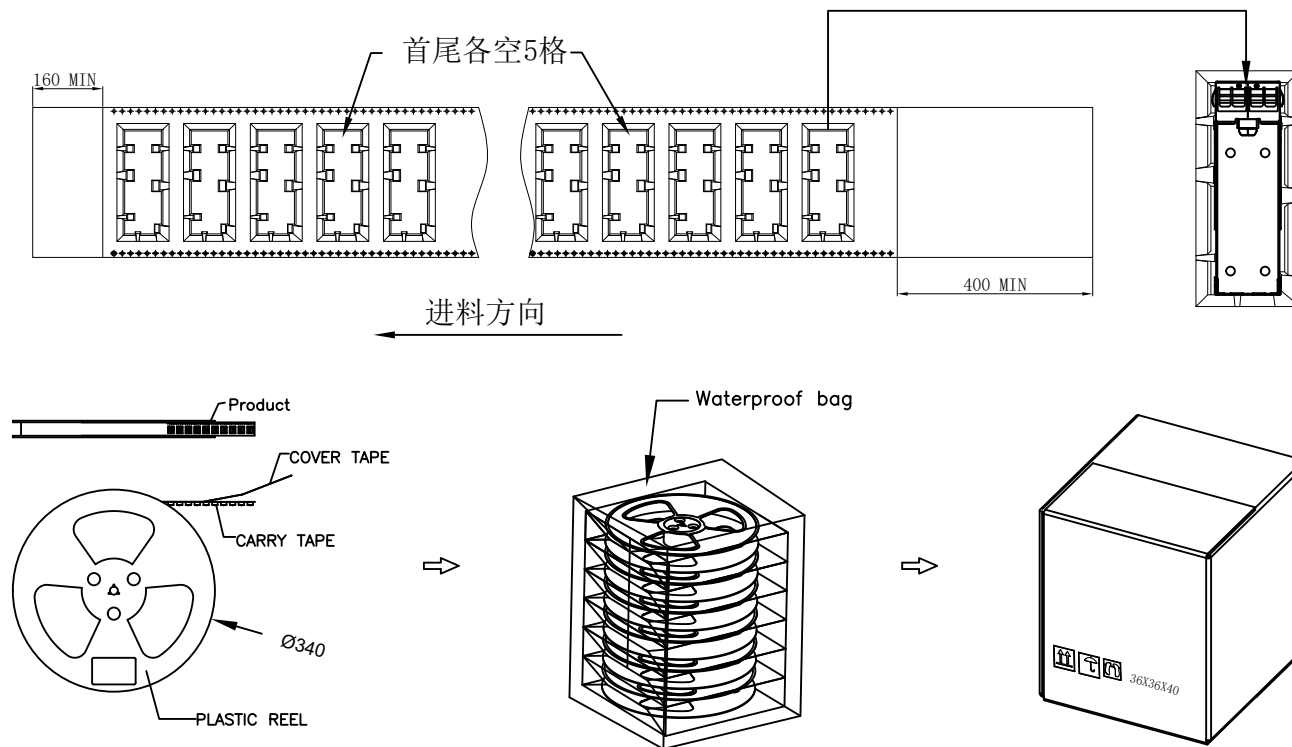

PACKING QUANTITY : 150 PCS FINISHED GOODS PER REEL.
 5 REEL (750 PCS FINISHED GOODS) PER CARTON BOX.

UNLESS OTHERWISE SPECIFIED TOLERANCE				
.X	1°			
.0	0.20	CHANT SINCERE CO.,LTD TEL:886-02-86471251 FAX:886-02-86472362		
.00	0.15			
.000	0.10			
SCALE:	AS SHOWN	UNIT: mm		
DRAWN:	PEARL	11/01/2018		
CHECKED:				
APPROVED:				
DRAWN NAME:		SFP+ CAGE .1X1 DIP WITH EMI SPRINGS 4/4		
PRODUCT NO.				
DRAWN NAME:		902AE11SW0C2X0C0		
FILE NAME:				
REV.	DESCRIPTION	DATE	SIZE A4 REV. X1	FILE NAME:

1	2	3	4	5	6	7	8	9	10
---	---	---	---	---	---	---	---	---	----