

NOTES:
 1. Electrical characteristics:
 1-1. Contact current rating:
 A current of DC 1.25A max. shall be applied collectively to A1,A4,A9,A12, B1,B4,B5,B9,B12, and DC 0.25A shall be applied collectively to other contacts.
 1-2. Contact resistance:
 40 Milliohms (MAX) initial for VBUS, GND and all other contacts. Maximum change (delta) of +10 Milliohms after environmental stresses.
 1-3. Dielectric withstanding voltage : 100 V AC MIN (RMS).
 1-4. Insulation resistance: 100 MEGOHMS MIN.
 2. Mechanical characteristics:
 2-1. Connector insertion force: 5~20N at a maximum rate of 12.5mm per minute.
 2-2. Connector extraction force: 8~20N up to 1000 mating cycles, and 6~20N after the specified insertion/extraction or durability cycles at a maximum rate of 12.5mm per minute.
 2-3. Durability: 10000 cycles minimum.
 2-4. Operating temperature: -55°C TO +85°C
 3. The connector is Rohs compliant and halogen free compliant.

PART NO.
317 D C 24 B S S F4 N 2 C X
 1 2 3 4 5 6 7 8 9 10 11 12

- 1.SERIES NO.
317=USB Series
- 2.D=SMT Type
- 3.GREEN OPTION:
C=RoHS2+HF
- 4.CONTACT NUMBER:
24=24 PINS
- 5.CONTACT TYPE:
B=FEMALE(LCP)
- 6.CONTACT AREA PLATING:
S=1u"GOLD
- 7.SOLDER TAILS AREA PLATING:
S=1u"GOLD
- 8.APPLY TYPE:
F4= Receptacl (Standard)
- 9.SHELL PLATING:
N=Ni
- 10.2=Center Height 1.68mm
- 11.PACKING STYLE:
C=Tap&Reel
- 12.INSULATOR COLOR:
3=Black
C=Black+D/C

7	Housing	1	Thermo Plastic	Molded Color: Black
6	Shield Plate	1	Stainless Steel	Ni Plating
5	Shell	1	Stainless Steel	Ni Plating
4	Upper I/M Insulator	1	Thermo Plastic	Molded Color: Black
3	Lower I/M Insulator	1	Thermo Plastic	Molded Color: Black
2	Lower Contact	12	Copper Alloy	Contact area: Gold flash over Ni. Solder tails: Gold flash over Ni.
1	Upper Contact	12	Copper Alloy	Contact area: Gold flash over Ni. Solder tails: Gold flash over Ni.
Item	Description	QTY	Material	Finish

UNLESS OTHERWISE SPECIFIED TOLERANCE

.X±0.25 X.* ±1*
.XX±0.15 .X.* ±0.5*

SCALE: AS SHOWN UNIT: mm

DRAWN RITA 04/19/2019

CHECKED / /

APPROVED / /

CHANT SINCERE CO.,LTD
 TEL:886-02-86471251 FAX:886-02-86472962

DRAWN NAME:
USB Type C 24Pin, RECP.Conn. 1/3

PRODUCT NO. 317DC24BSSF4N2CX

FILE NAME: 317DC24BSSF4N2C3(A07)

REV.	DESCRIPTION	DATE	SIZE	REV. C
1			A4	

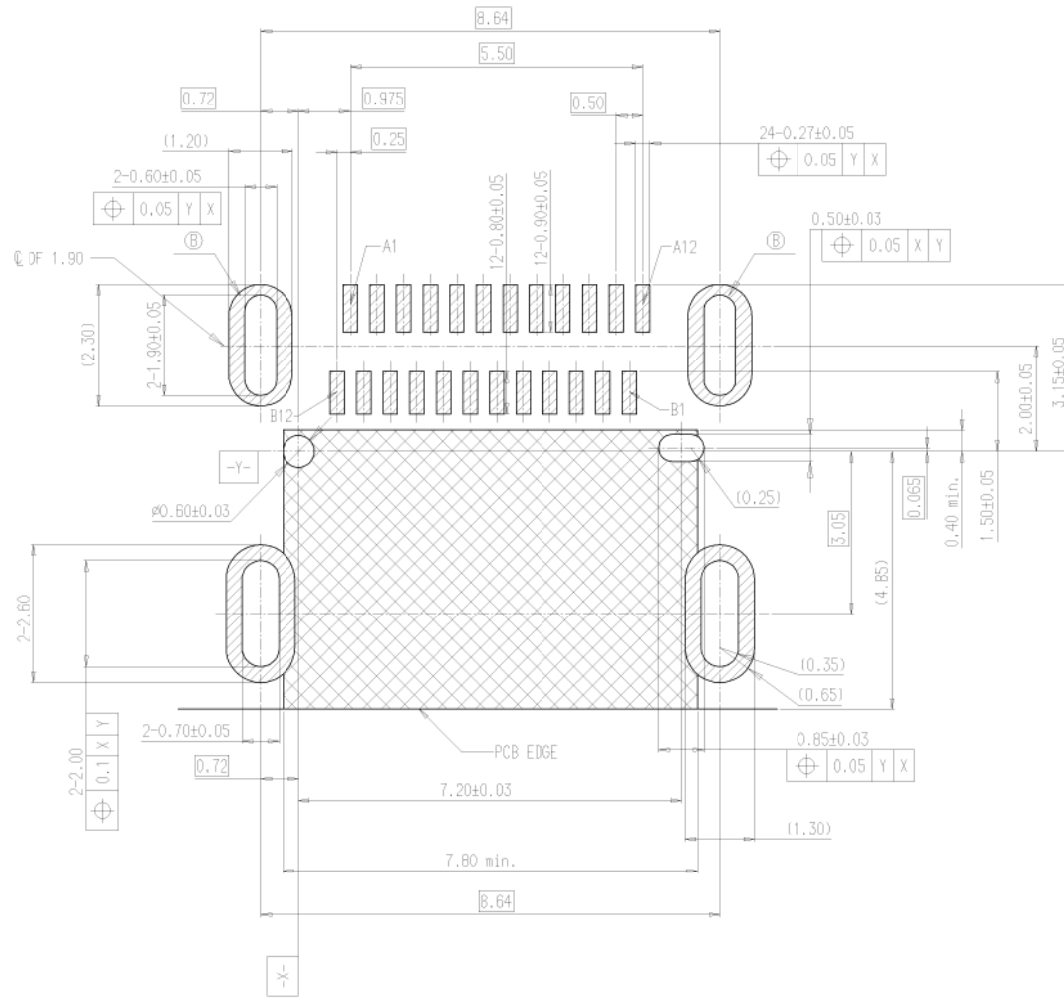

PIN ASSIGNMENT

Pin No.	Signal Name	Pin No.	Signal Name
A1	GND	B12	GND
A2	TX1+	B11	RX1+
A3	TX1-	B10	RX1-
A4	VBUS	B9	VBUS
A5	CC1	B8	SBU2
A6	D+	B7	D-
A7	D-	B6	D+
A8	SBU1	B5	CC2
A9	VBUS	B4	VBUS
A10	RX2-	B3	TX2-
A11	RX2+	B2	TX2+
A12	GND	B1	GND

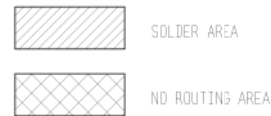

THE RECOMMEND PCB LAYOUT
DEFAULT TOLERANCE: ±0.05

UNLESS OTHERWISE SPECIFIED TOLERANCE

.X ±0.25	X.* ±1°
.XX ±0.15	.X.* ±0.5°



CHANT SINCERE CO., LTD
TEL:886-02-86471251 FAX:886-02-86472962

○ FOR SIP SCALE: AS SHOWN UNIT: mm

DRAWN	RITA	04/19/2019
CHECKED	/ /	
APPROVED	/ /	

DRAWN NAME: USB Type C 24Pin, RECP.Conn. 2/3

DATE SIZE A4 REV. C

PRODUCT NO. 317DC24BSSF4N2CX

REV.	DESCRIPTION	DATE

FILE NAME: 317DC24BSSF4N2C3(A07)

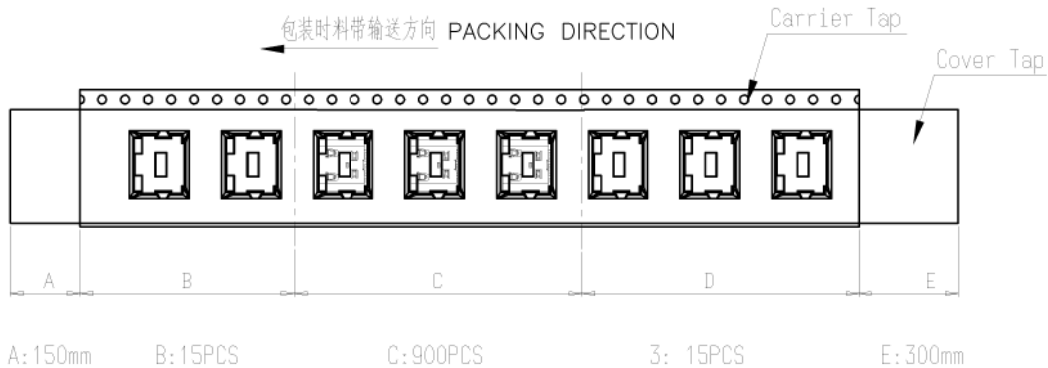
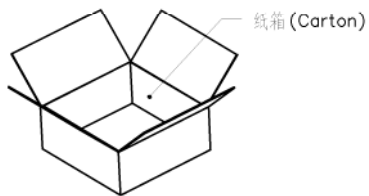
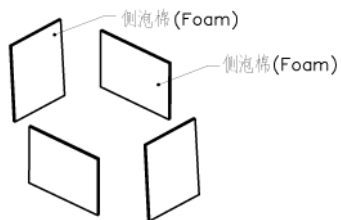
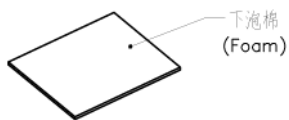
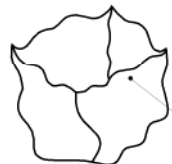
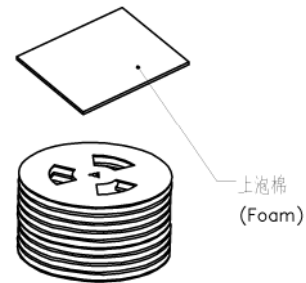

A: 150mm B: 15PCS C: 900PCS D: 15PCS E: 300mm

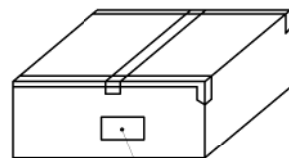
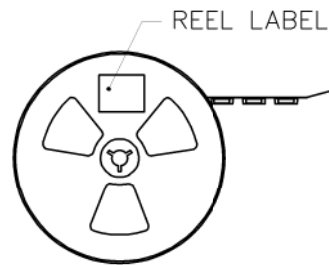
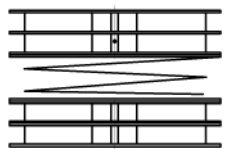

CARTON LABEL
900PCS/Reel
14Reel/CARTON

ITEMS	AMOUNT	Q"TY
CARTON	410X385X165	1PCS
Carrier Tap	14.88m/Reel	208.32m
Cover Tap	15.33m/Reel	214.62m

UNLESS OTHERWISE SPECIFIED TOLERANCE		 CHANT SINCERE CO.,LTD TEL:886-02-86471251 FAX:886-02-86472962	
SCALE: AS SHOWN	UNIT: mm	DRAWN NAME: USB Type C 24Pin, RECP.Conn. 3/3	
DRAWN RITA	04/19/2019	PRODUCT NO. 317DC24BSSF4N2CX	
CHECKED	/ /	FILE NAME: 317DC24BSSF4N2C3(A07)	
APPROVED	/ /		
REV. C			

REV.	DESCRIPTION	DATE	SIZE	A4