

3P-16P

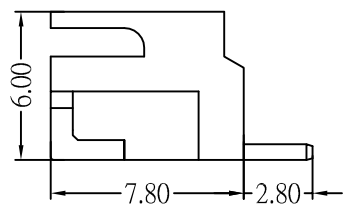
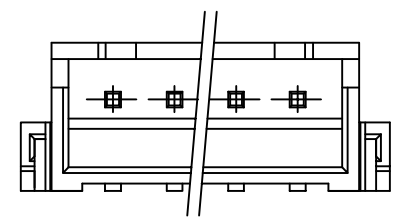
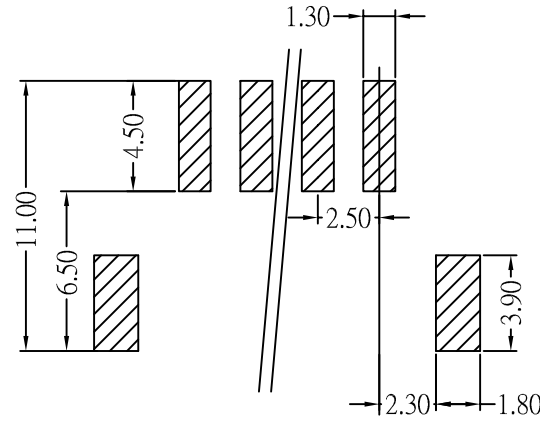

Circuits	DimA	DimB
2	2.5	10.0
3	5.0	12.5
4	7.5	15.0
5	10.0	17.5
6	12.5	20.0
7	15.0	22.5
8	17.5	25.0
9	20.0	27.5
10	22.5	30.0
11	25.0	32.5
12	27.5	35.0
13	30.0	37.5
14	32.5	40.0
15	35.0	42.5
16	37.5	45.0

Specifications

Current Rating: 3A AC, DC
 Voltage Rating: 250V AC Maximum
 Operating Temp: -25°C ~ +85°C
 Contact Resistance: 10mΩ Max
 Insulation Resistance: 1000MΩ Min
 Withstanding Voltage: 1000V AC/minute
 Pin: Brass/Gold Flash
 Wafer: Nylon 6T, UL94V-0
 Solder Tab: Brass/Gold Plated

PART NO.

311 D E XX M A T B2 R 3 D 1
 1 2 3 4 5 6 7 8 9 10 11 12

- | | |
|-------------------|--------------------|
| 1.SERIES NO. | 8.PITCH OPTION |
| 2.TYPE D=SMT | B2=2.50mm |
| 3.GREEN OPTION | 9.CONTACT OPTION |
| E=RoHS | R=Right Angle |
| 4.CONTACT NO. | 10.PROCESS OPTION |
| 02~16 | 3=TYPE 3 |
| 5.CONTACT TYPE | 11.PACKAGE OPTION |
| M=Male | D=Bag |
| 6.ROW TYPE | 12.INSULATOR COLOR |
| A=Single Row | 1=White |
| 7.CONTACT PLATING | |
| T=Tin Plated | |

2P

UNLESS OTHERWISE SPECIFIED TOLERANCE		 CHANT SINCERE CO., LTD TEL:886-02-86471251 FAX:886-02-86472962	
X'	±2'		
.0	±0.30		
.000	±0.10		
SCALE: AS SHOWN	UNIT: mm	DRAWN NAME: WAFER SMT Pitch 2.50mm PRODUCT NO. 311DEXXMATB2R3D1 FILE NAME: 311DEXXMATB2R3D1(W3)	
DRAWN PEARL	10/14/13		
CHECKED	/ /		
APPROVED	/ /		
REV.	DESCRIPTION	DATE	SIZE A4 REV. X1

REV.	DESCRIPTION	DATE