

MATERIALS AND FINISH

SHELL : STEEL MATERIAL, NICKEL FINISHED
 DIMPLES ON PLUG ONLY
 INSULATOR : PBT THERMOPLASTIC, 30% GLASS FILLED, UL 94V-0 RATED, BLACK COLOR
 CONTACT MATERIAL : BRASS
 CONTACT FINISH : SELECTIVE GOLD FLASH
 GROUNDING BRACKET : BRASS MATERIAL, TIN FINISHED
 JACK SCREWS : STEEL MATERIAL, NICKEL FINISHED WITH #4-40 THREADED ASSEMBLED

ELECTRICAL CHARACTERISTICS

CONTACT CURRENT RATING : 5.0 AMPS
 CONTACT RESISTANCE : 30 MILLIOHMS MAX.
 DIELECTRIC WITHSTANDING VOLTAGE : 1000 V AC MIN.
 INSULATION RESISTANCE : 5000 MEGAOHMS MIN.
 TEMPERATURE RATING : -55°C ~ +105°C

PART NO.

206 A E XX M X X B B X 3
 1 2 3 4 5 6 7 8 9 10 11

- | | |
|---|--|
| 1.SERIES NO. | 7.SHELL PLATING:
P=Tin Plated+Dimple |
| 2.TYPE: A=Standard | 8.PROCESS OPTION:
B=Rivet W/Boardlock |
| 3.GREEN OPTION:
E=RoHS(Bright) | 9.PARTS OPTION:
B=4#40 Thread Rivet |
| 4.CONTACT NUMBER:
09 15 25 37 | 10.PARTS DIMENSION
A=Non Accessories |
| 5.CONTACT TYPE:
M=Male | 11.INSULATOR:
3=Black |
| 6.CONTACT PLATING:
G=Gold Flash Over All | |

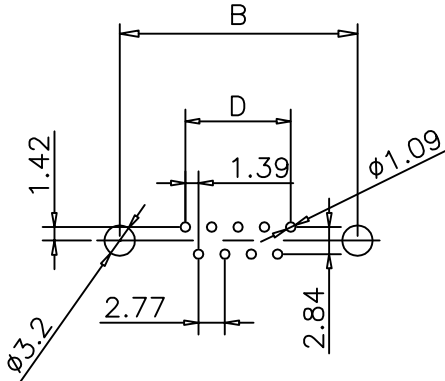
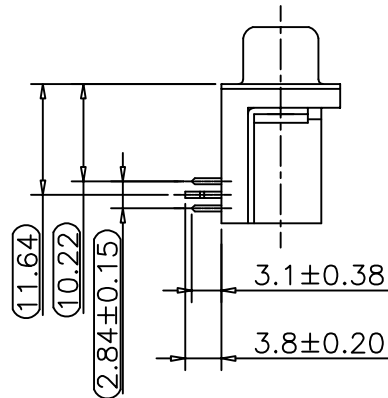
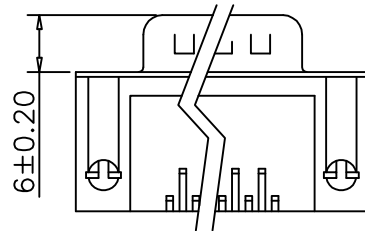

P.C.B LAYOUT

No. of Contact	A±0.20	B±0.20	C±0.20	D
09	16.90	24.99	30.81	11.08
15	26.38	33.32	39.14	19.39
25	39.94	47.04	53.04	33.24
37	56.43	63.50	69.32	49.86

For SIP

UNLESS OTHERWISE SPECIFIED TOLERANCE		
ANG.	±5°	
0.	±0.5	CHANT SINCERE CO., LTD TEL:886-02-86471251 FAX:886-02-86472962
.0	±0.3	
.00	±0.2	
SCALE: AS SHOWN	UNIT: mm	
DRAWN CHERRY	01/19/16'	DRAWN NAME: D-SUB PCB RIGHT ANGLE FOOTPRINT: 9.4mm (0.405")
CHECKED	/ /	PRODUCT NO. 206AXXXMXXBBX3
APPROVED	/ /	FILE NAME: 206AFXXMXXBBA3(H03)

REV.	DESCRIPTION	DATE	SIZE	REV.
1			A4	C