

P.C.B LAYOUT
TOL: 1.20 ± 0.05

Pin Number	Signal Name
1	VBUS
2	D-
3	D+
4	GND
5	SSRX-
6	SSRX+
7	GND
8	SSTX-
9	SSTX+
Shell	Shield

NOTE:
 1.MATERIAL:
 1.1 INSULATOR:PA9T BLUE Halogen-free
 1.2 CAP :LCP BLACK
 1.2 CONTACT:COPPER ALLOY
 1.3 SHELL:BRASS
 2.ELECTRICAL CHARACTERISTICS;
 2.1 CONTACT RESISTANCE: 30mΩ MAXIMUM
 2.2 CONTACT CURRENT RATING:1.5A
 2.3 DIELECTRIC WITHSTANDING VOLTAGE:100V R.M.S.
 2.4 INSULATION RESISTANCE 100 MEGOHMS MIN
 2.5 OPERATING TEMPERATURE:-20°C ~ 60°C
 3.PLATING
 3.1 TERMINAL:
 50u" MIN NICKEL ALL OVER
 100u"MIN Tin ON SOLDER AREA
 15u"Au ON CONTACT AREA
 3.2 SHELL:80u"MIN.NICEL ALL OVER
 3.3 Salt spray: 24H
 4.Reflow Profile:260*±5' 3~5 s

PART NO

377 A H 09 E X I S8 N A X 2
 1 2 3 4 5 6 7 8 9 10 11 12

- 1.SERIES NO. 377=USB Series 3.0
- 2.TYPE: A=Standard(Dip)
- 3.GREEN OPTION: H=RoHS+HF(Matte Plated)
- 4.CONTACT NUMBER: 09=9 Pin
- 5.CONTACT TYPE: F=Female
- 6.CONTACT AREA PLATING: S=Gold Flash, B=10u" Gold, C=15u" Gold, D=30u" Gold
- 7.SOLDER AREA PLATING: T=TIN
- 8.TYPE: S8=STANDARD(直立式A Type)
- 9.SHELL TYPE: N=Ni-Plated
- 10.DIM. A OPTION: A=H=12.5(DIP2.10)鐵殼無折邊直角
- 11.PACKING: A=Tray, C=Tape Reel
- 12.INSULATOR COLOR: 2=Blue(Pantone 653C), 3=Black, B=Blue+Logo, C=Black+Logo

For SIP

UNLESS OTHERWISE SPECIFIED TOLERANCE		
ANGLES +/-	2.0°	
x +/-	0.50	CHANT SINCERE CO.,LTD TEL:886-02-86471251 FAX:886-02-86472962
.x +/-	0.30	
.xx +/-	0.20	
SCALE: AS SHOWN	UNIT: mm	
DRAWN PEARL	01/31/2019	DRAWN NAME: USB 3.0 AF 180度 DIP H=12.5 一体式 无卷边 直脚[加防尘盖] 1/3
CHECKED	/ /	PRODUCT NO. 377AH09FXTS8NAC2
APPROVED	/ /	FILE NAME: 377AH09FXTS8NAC2(X02)

REV.	DESCRIPTION	DATE	SIZE	REV.
1			A4	C

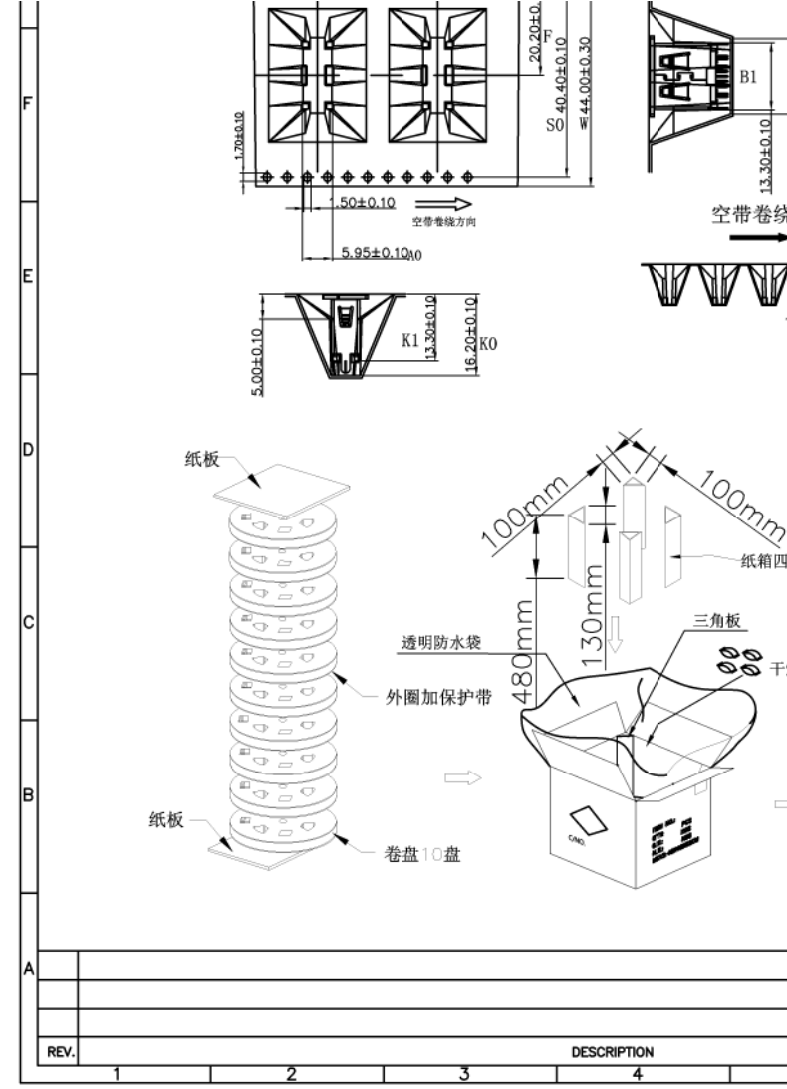
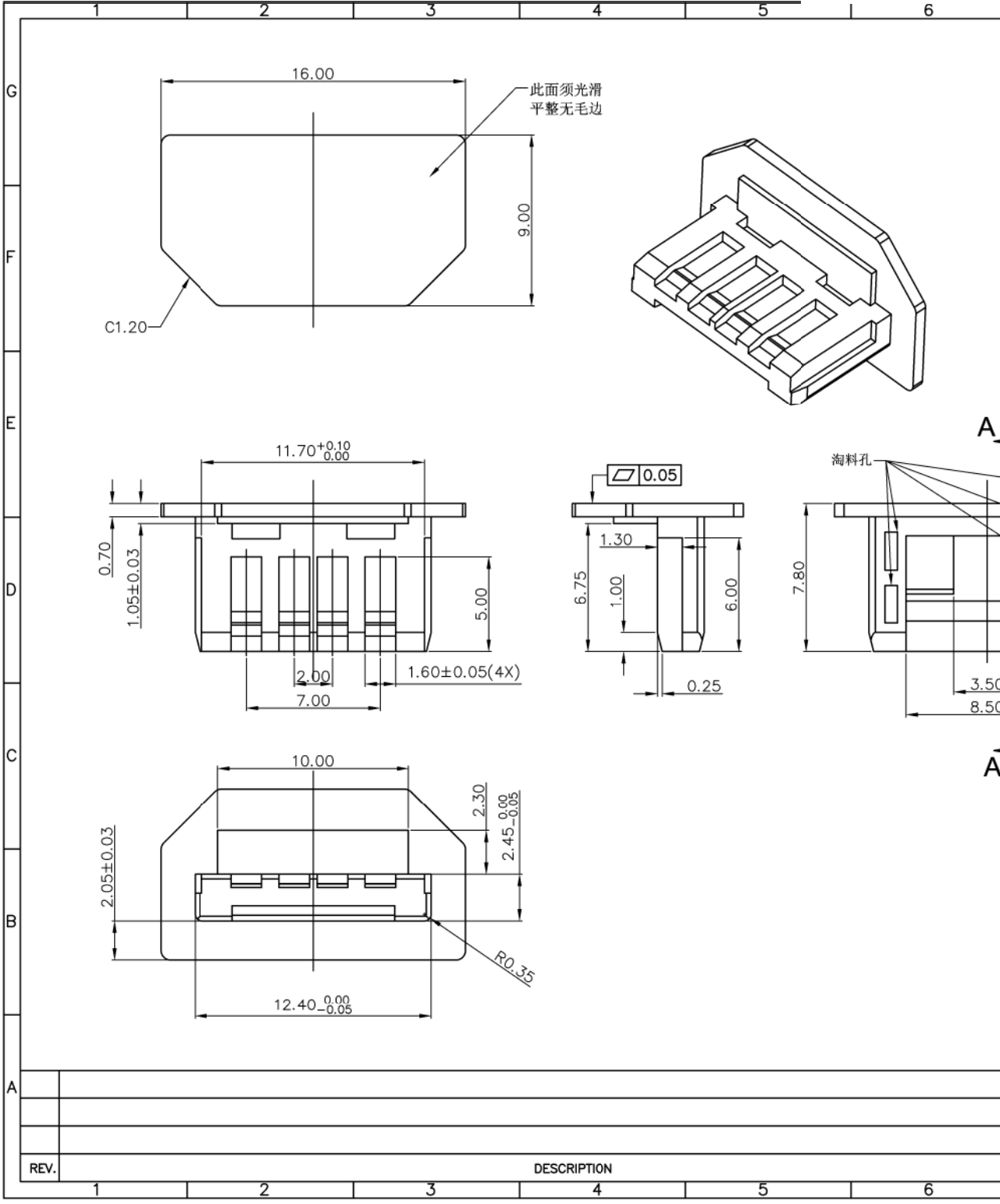

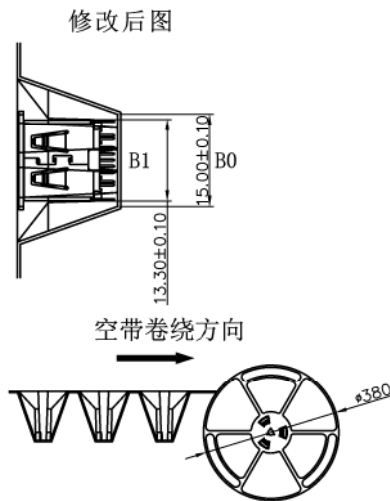
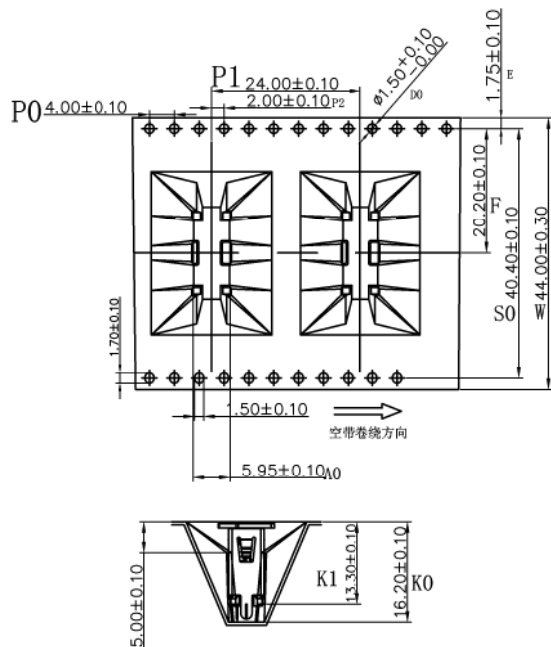

包装信息	
卷盘	380mmx44.4mm
卷盘信息	灰藍挖空旋轉
上带	37.5mmx200M
每盘格數	240pcs

品名	规格	单位	用量
载带	载带 W=44mm PH=24mm T=0.5mm 雾透PS 无卤	SET	1/240
盖带	自粘式透明上封带 W3.75mm T0.05mm	M	5.76/240
三角板	三角板10CM*10CM*13CM H48CM	PCS	4/2400
防水袋	PE袋, 80CMx80CM, T=0.05mm	PCS	1/2400
外箱	材质: K=K, 外径L40*W40*H52CM	PCS	1/2400

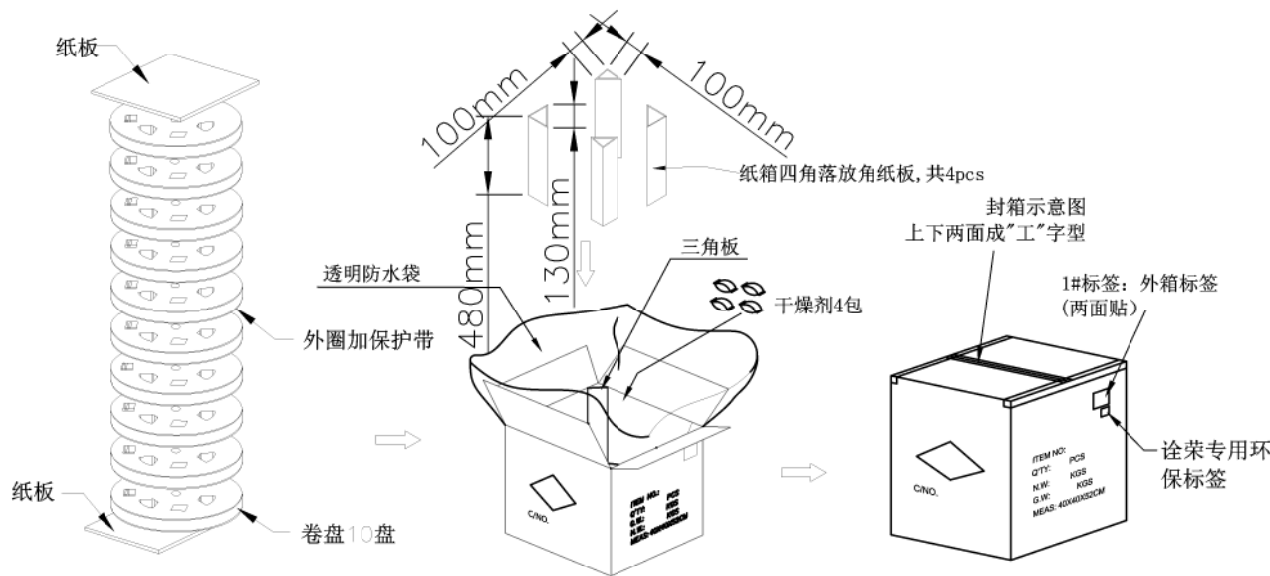

UNLESS OTHERWISE SPECIFIED TOLERANCE		 CHANT SINCERE CO., LTD TEL:886-02-86471251 FAX:886-02-86472962
SCALE: AS SHOWN	UNIT: mm	
DRAWN PEARL	01/31/2019	DRAWN NAME: USB 3.0 AF 180度 DIP H=12.5 一体式 无卷边 直脚[加防尘盖] 3/3
CHECKED	/ /	PRODUCT NO. 377AH09FXTS8NAC2
APPROVED	/ /	FILE NAME: 377AH09FXTS8NAC2(X02)

REV.	DESCRIPTION	DATE	SIZE	REV.
1			A4	C