

細部放大圖 C

SPECIFICATION
 MATERIAL
 Insulator: LCP, rated UL94V-0
 Contacts: C5210-RH
 Shell: SUS304 1/2H
 CONTACT PLATING

Underplate: 50u"~100u" Nickel
 Contact area: 1u"~15u" Selective gold
 Solder tails area: Gold Flash (Ref. 1u")

ELECTRICAL
 Operation voltage: 40 V
 Current rating: 0.5 Amps max.
 Contact resistance: 10 mohms initial
 Insulation resistance: 100 Mohms min @ 500 VDC
 Dielectric withstanding voltage: 500 VAC / minute
 Temperature range: -40°C TO +85°C
 Mating cycles: 5000 cycle

Part no.

908 D E 19 F X S D1 9 D C X
 1 2 3 4 5 6 7 8 9 10 11 12

- | | |
|---|---|
| 1.SERIES NO.
908=HDMI | 7.SOLDER TAILS AREA PLATING:
S=1u" GOLD |
| 2.D=SMT Type | 8.APPLY TYPE:
D1=D1 TYPE |
| 3.GREEN OPTION:
E=RoHS | 9.SHELL PLATING:
9=Stainless Steel (Matte) |
| 4.CONTACT NUMBER:
19=19 PINS | 10.D=Shell:DIP*4
(Single Molding) |
| 5.CONTACT TYPE:
F=FEMALE | 11.PACKING STYLE:
C=TAPE REEL |
| 6.CONTACT AREA PLATING:
S=GOLD FLASH
C=15u" GOLD
D=30u" GOLD | 12.INSULATOR COLOR:
3=Black
5=Beige
C=Black+Date Code
E=Beige+Date Code |

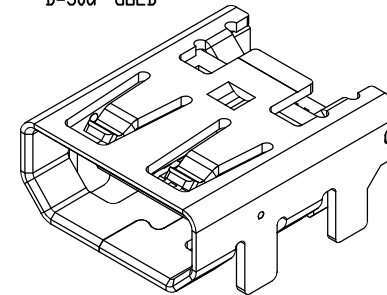

UNLESS OTHERWISE SPECIFIED TOLERANCE	
ANG.	± 2°
0.	± 0.30
.0	± 0.20
.00	± 0.10

SCALE: AS SHOWN UNIT: mm

DRAWN PEARL 10/08/2018
 CHECKED
 APPROVED



CHANT SINCERE CO.,LTD
 TEL:886-02-86471251 FAX:886-02-86472962

DRAWN NAME:
 HDMI D TYPE RECEPTACLE
 D1 TYPE (DIP*4) (1/2)
 PRODUCT NO. 908DE19FXSD19DCX

REV.	DESCRIPTION	DATE	SIZE	A4	REV.	C	FILE NAME:	C-908DE19FXSD19DCX
1								
2								
3								
4								
5								
6								
7								
8								
9								
10								

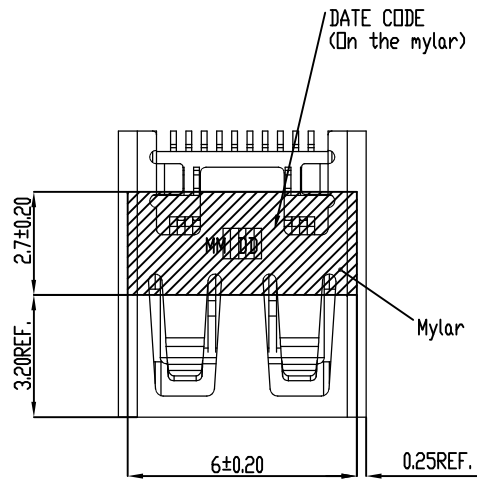

DATE CODE:
MM DD
 Month
 EX:06=JUNE
 Date
 EX:30=30th

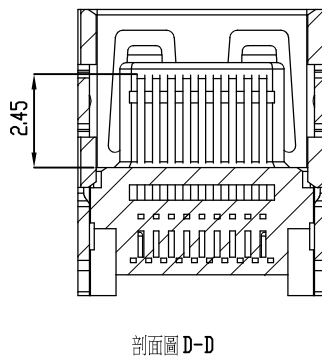
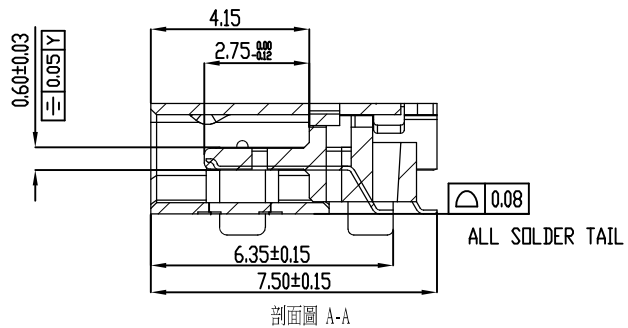
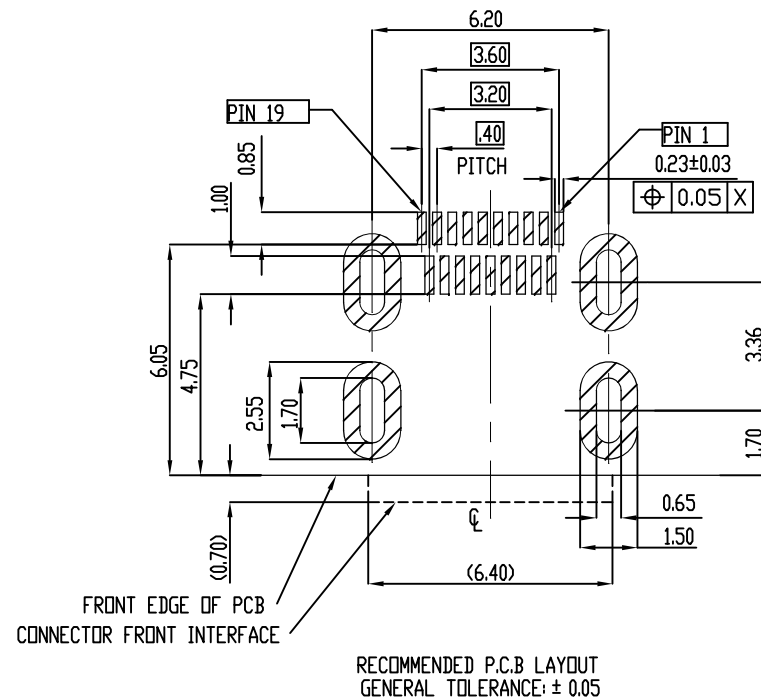
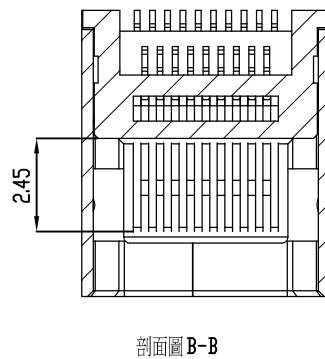

UNLESS OTHERWISE SPECIFIED TOLERANCE	
ANG.	± 2°
0.	± 0.30
.0	± 0.20
.00	± 0.10
SCALE:	AS SHOWN
UNIT:	mm
DRAWN	PEARL 10/08/2018
CHECKED	
APPROVED	



CHANT SINCERE CO.,LTD
 TEL:886-02-86471251 FAX:886-02-86472962
 DRAWN NAME:
 HDMI D TYPE RECEPTACLE
 D1 TYPE (DIP*4) (2/2)
 PRODUCT NO. 908DE19FXSD19DCX
 FILE NAME: C-908DE19FXSD19DCX

REV.	DESCRIPTION	DATE	SIZE	REV.
1			A4	C